

Oiles 500SP1 High-strength brass bearings with embedded solid lubricant

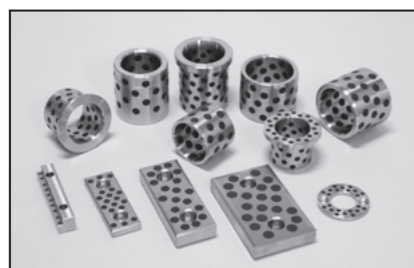

Feature

- Serviceable without the need for lubrication.
- Demonstrates high performance under high-load and low-speed operations.
- Demonstrates superior wear resistance in applications where oil film is seldom produced such as reciprocating motions, oscillation, frequent starts and stops, etc.
- Superior chemical resistance and corrosion resistance.
- Standard products are available in various sizes.

Service range	500SP1 SL1		500SP1 SL4
	Dry	periodic lubrication	Dry
Lubrication condition	Dry	periodic lubrication	Dry
Service temperature range °C	-40~+300	-40~+150	-40~+80
Allowable max. pressure P N/mm ² [kgf/cm ²]	29 (150) {296 (1,530)}		49 (150) {500 (1,530)}
Allowable max. velocity V m/s [m/min]	0.50 {30}	1.00 {60}	0.25 {15}
Allowable max. PV value N/mm ² · m/s [kgf/cm ² · m/min]	1.65 {1,010}	3.25 {1,990}	1.65 {1,010}

The values in parentheses are static bearing pressures, which are the bearing pressures in applications with no motion or very small motion ($\leq 0.0017\text{m/s}$ [0.1m/min]).

Mechanical properties

Density	—	g/cm ³	7.8
Tensile strength	JIS Z 2241	N/mm ² [kgf/mm ²]	755 {77}
Tensile elongation at break	JIS Z 2241	%	12
Compressive strength	—	N/mm ² [kgf/mm ²]	345 {35} (Note)
Impact strength	JIS Z 2242	J/cm ² [kgfm/cm ²]	19 {1.9}
Hardness	JIS Z 2243	HBW	210
Modulus of longitudinal elasticity	—	N/mm ² [kgf/mm ²]	105,000 {10,700}
Co-efficient of linear expansion	—	$\times 10^{-5} \text{ } ^\circ\text{C}^{-1}$	2.12
Thermal conductivity	—	W/m ² [cal/sec ² Ccm]	87.8 {0.21}

※ The values shown above are typical values, not the standard values.

(Note) Compressive strength is 0.1%

▲ When you use standard 500SP1 seires in the temperature of 150°C and over, contact us for more information.

▲ Refer to page 36 for the suitable solid lubricant for made-to-order bearings.

▲ Please indicate the type of motion (rotation, reciprocating, rotation & reciprocating) for custom-made products.

▲ Solid lubricant, SL401 and SL403 are not lead-free.

Lathe turning

		carbide tool (JIS)	
Cutting tool	Relief angle	5~10°	
	Rake angle	2~5°	
	Nose radius (mm)	0.40~0.80	
Condition	Speed (m/min)	100~200	
	Cut depth (mm)	0.05~0.30	
	Feed (mm/rev)	0.08~0.30	

Some products require application of solid lubricants on the sliding surface after processing.

※ Contact us for grinding and milling information.

Machining accuracy (bushing)

I.D.	O.D.	Length
class 7 to 8	class 6 to 7	class 8 to 9

Classes here are in JIS standard.

This product demonstrates satisfactory performance at the slide surface roughness of Rz6.3 to 12.5 μm .

Test data

Journal rotation test 500SP1-SL1

<Testing conditions>

Bearing dimension : $\phi 40 \times \phi 50 \times l 30$

Mating material : S45C high frequency quenched

Pressure : 24.5N/mm² {250.0kgf/cm²}

Velocity : 0.033m/s {2.0m/min}

Test time : 100hrs.

Ambience : in the atmosphere, room temp.

Lubrication : dry

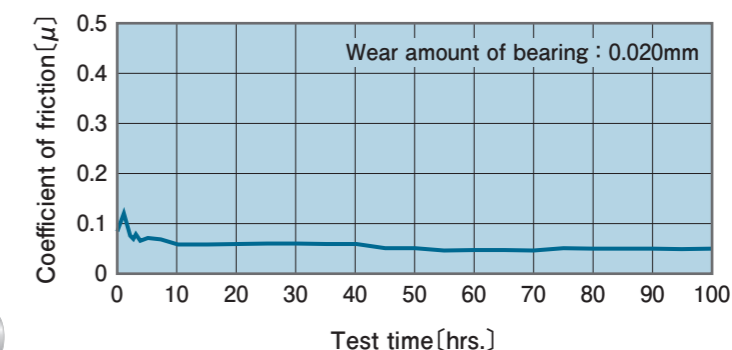
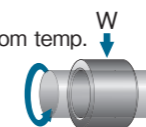

Journal oscillation test 500SP1-SL1

<Testing conditions>

Bearing dimension : $\phi 40 \times \phi 50 \times l 30$

Mating material : S45C

Pressure : 19.6N/mm² {200.0kgf/cm²}

Velocity : 0.025m/s {1.5m/min}

Oscillating cycle : 24cpm

Oscillating angle : $\pm 45^\circ$

Test time : 168hrs.

Ambience : in the atmosphere, room temp.

Lubrication : dry

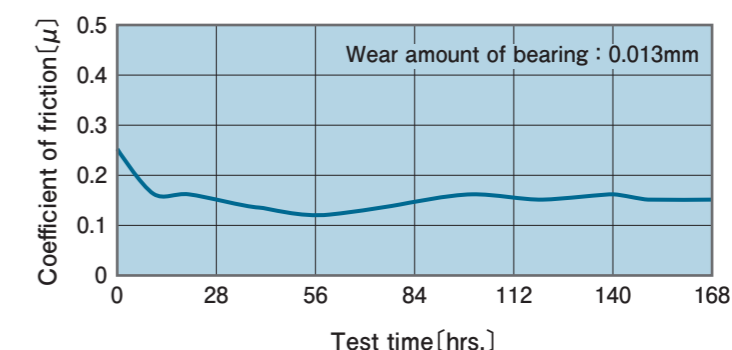
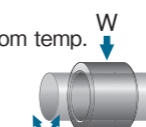

Journal oscillation test 500SP1-SL4

<Testing conditions>

Bearing dimension : $\phi 40 \times \phi 50 \times l 30$

Mating material : SUS304

Pressure : 29.4N/mm² {300kgf/cm²}

Velocity : 0.012m/s {0.75m/min}

Oscillating cycle : 12cpm

Oscillating angle : $\pm 45^\circ$

Test cycle : 70,000cycle (97.2h)

Ambience : in the atmosphere, room temp.

Lubrication : initial grease SL464g coating

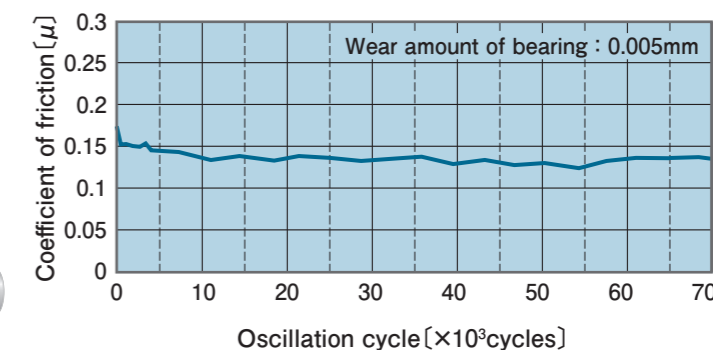
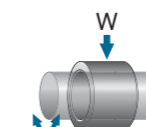

Journal oscillation test 500SP1-SL4

<Testing conditions>

Bearing dimension : $\phi 60 \times \phi 75 \times l 50$

Mating material : SUS403

Pressure : 24.5N/mm² {250kgf/cm²}

Velocity : 0.018m/s {1.13m/min}

Oscillating cycle : 12cpm

Oscillating angle : $\pm 45^\circ$

Test cycle : 70,000cycle (97.2h)

Ambience : in the purified water

Lubrication : initial grease SL464g coating

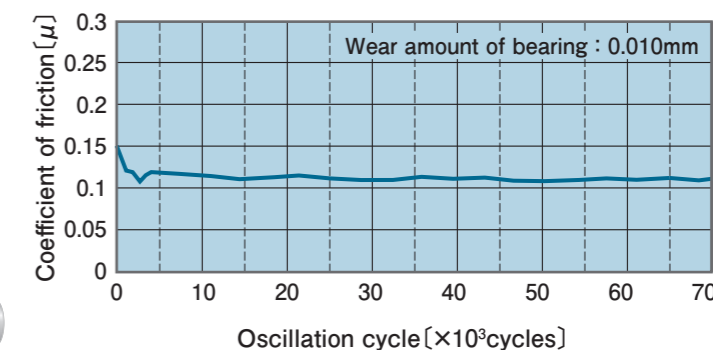
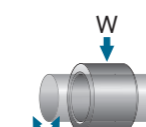



Specify Part No. by required I.D., O.D. and Length.
(e.g.) I.D. is 25mm, O.D. is 33mm, and length is 20mm.

SPB - 253320
Part No.

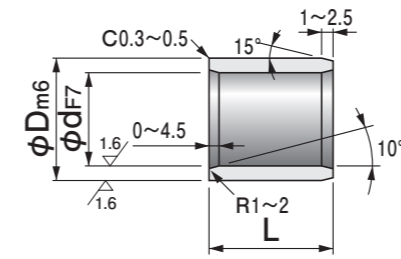
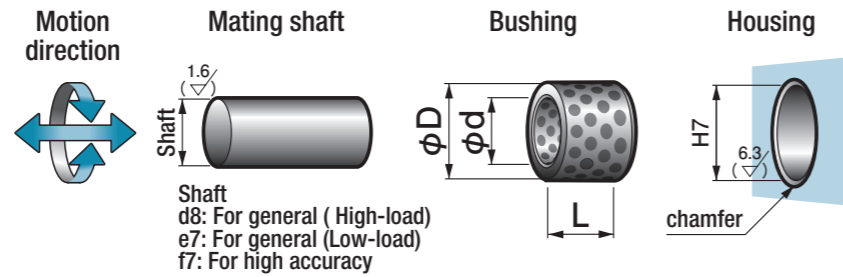

It is recommended to use a set screw to prevent dislocation.

Use this product together with the Oiles #500SP washer (SPW shown on page 197) in a position where thrust loads are applied.

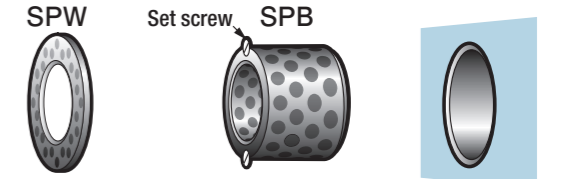

※Be sure to determine the position with a countersunk head screw and fix when the SPW with ★ shown in the table below is used, since the inner diameter is larger than the shaft diameter.

- Applicable to rotation, oscillation, and reciprocating motion.
- Do not use this under water.
- 31.5mm I.D. bushing can be used as an intermediate trunnion bushing for hydraulic cylinders.

All SPB bushings have engraved **OILES** mark.

I.D.		O.D.		Length L							Tolerance $\begin{matrix} -0.1 \\ -0.3 \end{matrix}$		
φd	Tolerance	φD	Tolerance	8	10	12	15	16	19	20	25		
6	+0.022 +0.010	10	+0.015 +0.006	061008	061010	061012							
8	+0.028 +0.013	12	+0.018 +0.007	081208	081210	081212	081215						
10	+0.028 +0.013	14	+0.018 +0.007	101408	101410	101412	101415			101420			
12	+0.034 +0.016	18	+0.018 +0.007	121808	121810	121812	121815	121816	121819	121820	121825		
13	+0.034 +0.016	19	+0.021 +0.008		131910	131912	131915			131920	131925		
14	+0.034 +0.016	20	+0.021 +0.008		142010	142012	142015			142020	142025		
15	+0.034 +0.016	21	+0.021 +0.008		152110	152112	152115	152116		152120	152125		
16	+0.034 +0.016	22	+0.021 +0.008		162210	162212	162215	162216	162219	162220	162225		
17	+0.034 +0.016	23	+0.021 +0.008				172315						
18	+0.034 +0.016	24	+0.021 +0.008		182410	182412	182415	182416		182420	182425		
19	+0.041 +0.020	26	+0.021 +0.008				192615			192620			
20	+0.041 +0.020	28	+0.021 +0.008		202810	202812	202815	202816	202819	202820	202825		
20	+0.041 +0.020	30	+0.021 +0.008		203010	203012	203015	203016		203020	203025		
22	+0.041 +0.020	32	+0.025 +0.009			223212	223215			223220	223225		
25	+0.041 +0.020	33	+0.025 +0.009			253312	253315	253316		253320	253325		
25	+0.041 +0.020	35	+0.025 +0.009			253512	253515	253516		253520	253525		
28	+0.041 +0.020	38	+0.025 +0.009							283820	283825		
30	+0.041 +0.020	38	+0.025 +0.009			303812	303815			303820	303825		
30	+0.041 +0.020	40	+0.025 +0.009			304012	304015			304020	304025		
31.5	+0.050 +0.025	40	+0.025 +0.009										
32	+0.050 +0.025	42	+0.025 +0.009							324220			
35	+0.050 +0.025	44	+0.025 +0.009							354420	354425		
35	+0.050 +0.025	45	+0.025 +0.009							354520	354525		
38	+0.050 +0.025	48	+0.025 +0.009										
40	+0.050 +0.025	50	+0.025 +0.009				405015			405020	405025		
40	+0.050 +0.025	55	+0.030 +0.011				405515						
45	+0.050 +0.025	55	+0.030 +0.011										
45	+0.050 +0.025	56	+0.030 +0.011										
45	+0.050 +0.025	60	+0.030 +0.011										

※The I.D. tolerance after press fitting is for reference only.
※I.D. φ50~φ200 are shown on pages 189 to 190.

▲The dimensional tolerances are the values measured at +25°C.

Length L							Tolerance $\begin{matrix} -0.1 \\ -0.3 \end{matrix}$		I.D. tolerance after press fitting (reference)	Washer SPW	I.D. φd
30	35	40	50	60	70	80					
								+0.019 +0.007	0603	6	
								+0.025 +0.010	0803	8	
								+0.025 +0.010	1003	10	
121830								+0.031 +0.013	1203	12	
131930								+0.030 +0.012	1303	13	
142030								+0.030 +0.012	1403	14	
152130	152135	152140						+0.030 +0.012	1503	15	
162230	162235	162240						+0.030 +0.012	1603	16	
								+0.030 +0.012	1803★	17	
182430	182435	182440						+0.030 +0.012	1803	18	
								+0.037 +0.016	2005★	19	
202830	202835	202840	202850					+0.037 +0.016	2005	20	
203030	203035	203040	203050					+0.037 +0.016	2505★	20	
								+0.037 +0.016	2505★	22	
253330	253335	253340	253350	253360				+0.037 +0.016	2505	25	
253530	253535	253540	253550	253560				+0.037 +0.016	3005★	25	
283830		283840						+0.037 +0.016	3005★	28	
303830	303835	303840	303850	303860				+0.037 +0.016	3005	30	
304030	304035	304040	304050	304060				+0.037 +0.016	3505★	30	
314030		314040						+0.046 +0.021	3505★	31.5	
324230		324240						+0.046 +0.021	3505★	32	
354430	354435	354440	354450	354460				+0.046 +0.021	3505	35	
354530	354535	354540	354550	354560				+0.046 +0.021	4007★	35	
		384840						+0.046 +0.021	4007★	38	
405030	405035	405040	405050	405060	405070	405080		+0.046 +0.021	4007	40	
405530	405535	405540	405550	405560				+0.045 +0.020	4507★	40	
455530	455535	455540	455550	455560				+0.045 +0.020	4507	45	
455630	455635	455640	455650	455660				+0.045 +0.020	4507	45	
456030	456035	456040	456050	456060	456070	456080		+0.045 +0.020	4507	45	



Specify Part No. by required I.D., O.D. and Length.
(e.g.) I.D. is 80mm, O.D. is 96mm, and length is 70mm.

SPB - 809670
Part No.

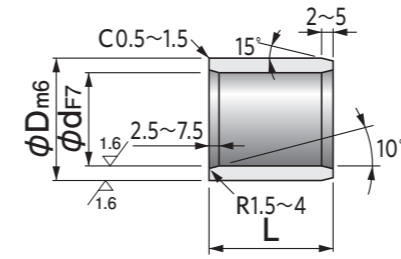
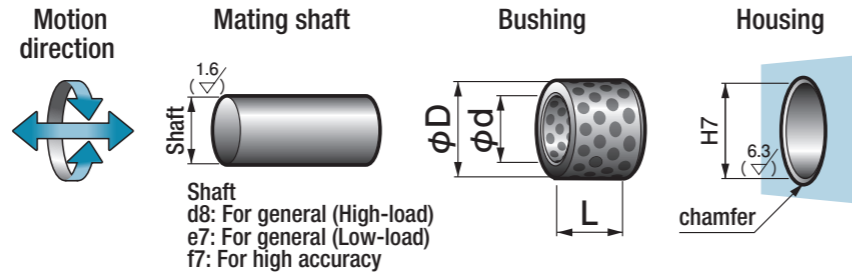

It is recommended to use a set screw to prevent dislocation.

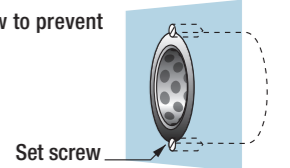

Use this product together with the Oiles #500SP washer (SPW shown on page 197) in a position where thrust loads are applied.

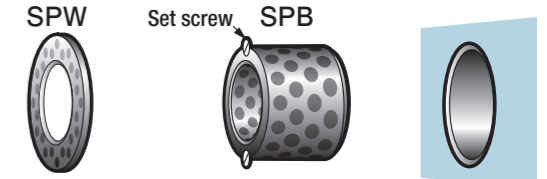

※Be sure to determine the position with a countersunk head screw and fix when the SPW with ★ shown in the table below is used, since the inner diameter is larger than the shaft diameter.

- Applicable to rotation, oscillation, and reciprocating motion.
- Do not use this under water.
- 63mm I.D bushing can be used as an intermediate trunnion bushing for hydraulic cylinders.

All SPB bushings have engraved **OILES** mark.

I.D.		O.D.		Length L Tolerance $\begin{matrix} -0.1 \\ -0.3 \end{matrix}$							
ϕd	Tolerance	ϕD	Tolerance	20	30	35	40	50	60	70	80
50	+0.050 +0.025	60	+0.030 +0.011	506020	506030	506035	506040	506050	506060	506070	506080
50	+0.050 +0.025	62	+0.030 +0.011		506230	506235	506240	506250	506260	506270	506280
50	+0.050 +0.025	65	+0.030 +0.011		506530		506540	506550	506560	506570	506580
55	+0.060 +0.030	70	+0.030 +0.011		557030	557035	557040	557050	557060	557070	
60	+0.060 +0.030	74	+0.030 +0.011		607430	607435	607440	607450	607460	607470	607480
60	+0.060 +0.030	75	+0.030 +0.011		607530	607535	607540	607550	607560	607570	607580
63	+0.060 +0.030	75	+0.030 +0.011						637560	637570	637580
65	+0.060 +0.030	80	+0.030 +0.011				658040	658050	658060	658070	658080
70	+0.060 +0.030	85	+0.035 +0.013		708530	708535	708540	708550	708560	708570	708580
70	+0.060 +0.030	90	+0.035 +0.013					709050	709060	709070	709080
75	+0.060 +0.030	90	+0.035 +0.013					759050	759060	759070	759080
75	+0.060 +0.030	95	+0.035 +0.013						759560	759570	759580
80	+0.060 +0.030	96	+0.035 +0.013				809640	809650	809660	809670	809680
80	+0.060 +0.030	100	+0.035 +0.013				8010040	8010050	8010060	8010070	8010080
85	+0.071 +0.036	100	+0.035 +0.013						8510060		8510080
90	+0.071 +0.036	110	+0.035 +0.013					9011050	9011060		9011080
100	+0.071 +0.036	120	+0.035 +0.013					10012050	10012060	10012070	10012080
110	+0.071 +0.036	130	+0.040 +0.015					11013050		11013070	11013080
120	+0.071 +0.036	140	+0.040 +0.015							12014070	12014080
125	+0.083 +0.043	145	+0.040 +0.015								
130	+0.083 +0.043	150	+0.040 +0.015								13015080
140	+0.083 +0.043	160	+0.040 +0.015								
150	+0.083 +0.043	170	+0.040 +0.015								15017080
160	+0.083 +0.043	180	+0.040 +0.015								16018080
170	+0.083 +0.043	190	+0.046 +0.017								
180	+0.083 +0.043	200	+0.046 +0.017								
190	+0.096 +0.050	210	+0.046 +0.017								
200	+0.096 +0.050	230	+0.046 +0.017								

※Part No. with * are custom-made.

※The I.D. tolerance after press fitting is for reference only.

※I.D. ϕ 6~ ϕ 45 are shown on pages 187 to 188.

▲ The dimensional tolerances are the values measured at +25°C.

Length L Tolerance $\begin{matrix} -0.1 \\ -0.3 \end{matrix}$							I.D. tolerance after press fitting (reference)	Washer	I.D.
90	100	120	130	140	150	200		SPW	ϕd
							+0.045 +0.020	5008	50
							+0.045 +0.020	5008	50
	5065100						+0.045 +0.020	5008	50
							+0.055 +0.025	5508	55
							+0.055 +0.025	6008	60
	6075100						+0.055 +0.025	6008	60
							+0.055 +0.025	6508★	63
							+0.055 +0.025	6508	65
	7085100						+0.054 +0.024	7010	70
							+0.054 +0.024	7010	70
	7590100						+0.054 +0.024	7510	75
	7595100						+0.054 +0.024	7510	75
	8096100	8096120					+0.054 +0.024	8010	80
	80100100	80100120			80100140		+0.054 +0.024	8010	80
							+0.065 +0.030	9010★	85
9011090	90110100	90110120					+0.065 +0.030	9010	90
10012090	100120100	100120120			100120140		+0.065 +0.030	10010	100
	110130100	110130120					+0.064 +0.029	12010★	110
12014090	120140100	120140120			120140140		+0.064 +0.029	12010	120
	125145100	125145120					+0.076 +0.036	—	125
	130150100			130150130			+0.076 +0.036	—	130
	140160100			140160140			+0.076 +0.036	—	140
	150170100				150170150		+0.076 +0.036	—	150
	160180100				160180150		+0.076 +0.036	—	160
	*170190100				*170190150		+0.076 +0.036	—	170
	*180200100				*180200150		+0.076 +0.036	—	180
	*190210100				*190210150		+0.088 +0.042	—	190
					*200230150	*200230200	+0.088 +0.042	—	200



Specify Part No. by required I.D., O.D. and Length.
(e.g.) I.D. is 60mm, O.D. is 75mm, and length is 80mm.

SPBL - 607580

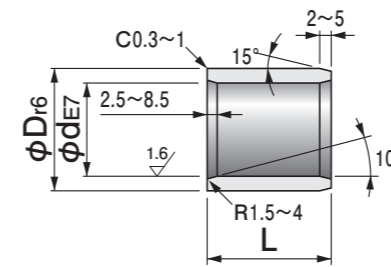
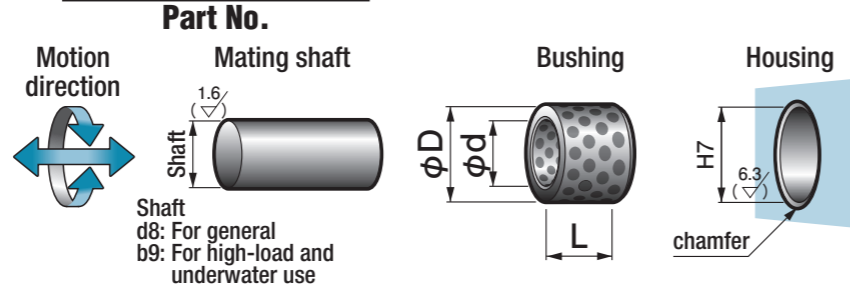

- Applicable to rotational, oscillating, and reciprocating motion.
- Be sure to apply grease supplied with the product to the inner sliding surface before assembling the bearing. Run in the bearing.
- May be used over the maximum allowable speed or maximum allowable PV value in short-time intermittent operations. Inquire us in such a case.
- Use a stainless steel or chrome-plated (30μm or more) mating shaft when using the product in water, in a water-splashed place, etc.
- Use a mating shaft made of high-grade stainless steel with higher corrosion resistance or plated with thicker chrome when using the product in severe corrosive conditions. Supply grease for rust prevention.
- Provide the bushing with a set screw when using the product for high loads.
- Usable without the need for lubrication in the air and water. Use lithium grease with extreme pressure additive if greasing is required.

※Operating Temperature Range: -40~ +80°C (-40~ +176°F) Solid Lubricant : SL464 (refer to page 36)

I.D.		O.D.		Length L								I.D. tolerance after press fitting (reference)		I.D.
φd	Tolerance	φD	Tolerance	20	25	30	35	40	50	60	70	80	φd	
12	+0.050 +0.032	18	+0.034 +0.023	121820									+0.031 +0.013	12
15	+0.050 +0.032	21	+0.041 +0.028	152120									+0.026 +0.008	15
16	+0.050 +0.032	22	+0.041 +0.028	162220		162230							+0.026 +0.008	16
18	+0.050 +0.032	24	+0.041 +0.028	182420									+0.026 +0.008	18
20	+0.061 +0.040	30	+0.041 +0.028	203020		203030		203040					+0.037 +0.016	20
25	+0.061 +0.040	35	+0.050 +0.034	253520	253525	253530		253540	253550				+0.032 +0.011	25
30	+0.061 +0.040	40	+0.050 +0.034	304020	304025	304030		304040	304050				+0.046 +0.021	30
35	+0.075 +0.050	45	+0.050 +0.034	354520		354530	354535	354540	354550	354560			+0.046 +0.021	35
40	+0.075 +0.050	50	+0.050 +0.034			405030		405040	405050	405060			+0.040 +0.015	40
40	+0.075 +0.050	55	+0.060 +0.041					405540	405550	405560			+0.040 +0.015	40
45	+0.075 +0.050	60	+0.060 +0.041			456030			456050	456060			+0.040 +0.015	45
50	+0.075 +0.050	60	+0.060 +0.041					506040	506050	506060			+0.040 +0.015	50
50	+0.075 +0.050	65	+0.060 +0.041					506540	506550	506560	506570		+0.040 +0.015	50
55	+0.090 +0.060	70	+0.062 +0.043					557040		557060	557070		+0.053 +0.023	55
60	+0.090 +0.060	75	+0.062 +0.043						607550	607560	607570	607580	+0.053 +0.023	60
65	+0.090 +0.060	80	+0.062 +0.043							658060	658070	658080	+0.053 +0.023	65
70	+0.090 +0.060	90	+0.073 +0.051							709060	709070	709080	+0.046 +0.016	70
75	+0.090 +0.060	95	+0.073 +0.051								759570		+0.046 +0.016	75
80	+0.090 +0.060	100	+0.073 +0.051							801060		801080	+0.046 +0.016	80
90	+0.107 +0.072	110	+0.076 +0.054							9011060		9011080	+0.060 +0.025	90
100	+0.107 +0.072	120	+0.076 +0.054							10012060		10012080	+0.060 +0.025	100
110	+0.107 +0.072	130	+0.088 +0.063										+0.052 +0.017	110
120	+0.107 +0.072	140	+0.088 +0.063										+0.052 +0.017	120
130	+0.125 +0.085	150	+0.090 +0.065										+0.068 +0.028	130
140	+0.125 +0.085	160	+0.090 +0.065										+0.068 +0.028	140
150	+0.125 +0.085	170	+0.093 +0.068										+0.065 +0.025	150
160	+0.125 +0.085	180	+0.093 +0.068										+0.065 +0.025	160
170	+0.125 +0.085	190	+0.106 +0.077										+0.065 +0.025	170
180	+0.125 +0.085	200	+0.106 +0.077										+0.065 +0.025	180
190	+0.146 +0.100	210	+0.109 +0.080										+0.078 +0.032	190
200	+0.146 +0.100	230	+0.113 +0.084										+0.078 +0.032	200

※Part No. with * are made-to-order.

※The I.D. tolerance after press fitting is for reference only.

▲ The dimensional tolerances are the values measured at +25°C.

Length L								I.D. tolerance after press fitting (reference)		I.D.
90	100	110	120	130	140	150	200	φd		φd
								+0.031 +0.013		12
								+0.026 +0.008		15
								+0.026 +0.008		16
								+0.026 +0.008		18
								+0.037 +0.016		20
								+0.032 +0.011		25
								+0.032 +0.011		30
								+0.046 +0.021		35
								+0.046 +0.021		40
								+0.040 +0.015		40
								+0.040 +0.015		45
								+0.040 +0.015		50
								+0.040 +0.015		50
								+0.053 +0.023		55
								+0.053 +0.023		60
								+0.053 +0.023		65
709090	7090100							+0.046 +0.016		70
	7595100							+0.046 +0.016		75
8010090	80100100	80100110						+0.046 +0.016		80
9011090	90110100							+0.060 +0.025		90
	100120100		100120120					+0.060 +0.025		100
	110130100	110130110						+0.052 +0.017		110
	120140100		120140120					+0.052 +0.017		120
	130150100			130150130		130150150		+0.068 +0.028		130
	140160100				140160140			+0.068 +0.028		140
	150170100					150170150		+0.065 +0.025		150
	160180100					160180150		+0.065 +0.025		160
	*170190100					*170190150		+0.065 +0.025		170
	*180200100					*180200150		+0.065 +0.025		180
	*190210100					*190210150		+0.078 +0.032		190
						*200230150	*200230200	+0.078 +0.032		200

SPF Oiles 500SP1 SL1 Flange Bushings

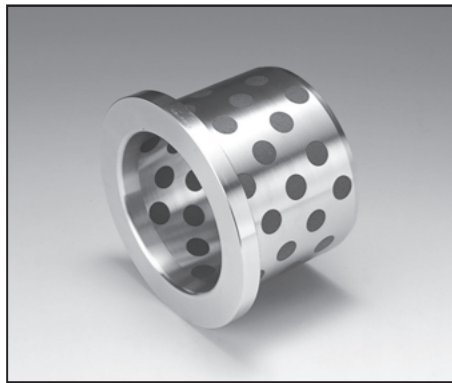

Specify Part No. by required I.D. and Length.
(e.g.) I.D. is 50mm and length is 30mm.

SPF - 5030
Part No.

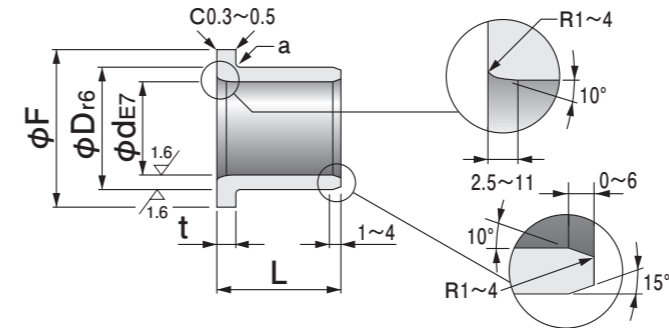
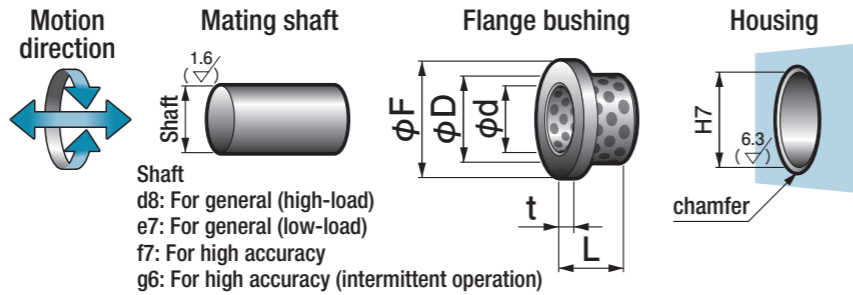

a: Chamfering for under flange

phi d	~18	~65	~160
a	R0.3	R0.5	R1

 (mm)
 ★ 4 model number of SPF-6040/6050/6080/6367 is R1.

- Applicable to rotational, oscillating, and reciprocating motion.
- Flange surface is not subject to a thrust load as no lubricant is embedded.
- Do not use this under water.
- 31.5mm I.D. and 63mm I.D bushing can be used as an intermediate trunnion bushing for hydraulic cylinders.

I.D.		O.D.		Flange				Length L Tolerance -0.1 -0.3							
phi d	Tolerance	phi D	Tolerance	phi F	Tolerance	t	Tolerance	10	12	15	17	18	20	23	25
6	+0.032 +0.020	10	+0.028 +0.019	16	0 -0.3	2	0 -0.1	0610	0612						
8	+0.040 +0.025	12	+0.034 +0.023	20	0 -0.3	2	0 -0.1	0810	0812	0815					
10	+0.040 +0.025	14	+0.034 +0.023	22	0 -0.3	2	0 -0.1	1010	1012	1015	1017		1020		
12	+0.050 +0.032	18	+0.034 +0.023	25	0 -0.3	3	0 -0.1	1210	1212	1215			1220		1225
13	+0.050 +0.032	19	+0.041 +0.028	26	0 -0.3	3	0 -0.1	1310	1312	1315			1320		1325
14	+0.050 +0.032	20	+0.041 +0.028	27	0 -0.3	3	0 -0.1			1415			1420		1425
15	+0.050 +0.032	21	+0.041 +0.028	28	0 -0.3	3	0 -0.1	1510	1512	1515			1520		1525
16	+0.050 +0.032	22	+0.041 +0.028	29	0 -0.3	3	0 -0.1		1612	1615		1618	1620	1623	1625
18	+0.050 +0.032	24	+0.041 +0.028	32	0 -0.3	3	0 -0.1			1815			1820		1825
20	+0.061 +0.040	30	+0.041 +0.028	40	0 -0.3	5	0 -0.1			2015			2020		2025
25	+0.061 +0.040	35	+0.050 +0.034	45	0 -0.3	5	0 -0.1			2515			2520		2525
30	+0.061 +0.040	40	+0.050 +0.034	50	0 -0.3	5	0 -0.1						3020		3025
31.5	+0.075 +0.050	40	+0.050 +0.034	50	0 -0.3	5	0 -0.1						3120		
35	+0.075 +0.050	45	+0.050 +0.034	60	0 -0.3	5	0 -0.1						3520		3525
40	+0.075 +0.050	50	+0.050 +0.034	65	0 -0.3	5	0 -0.1						4020		4025
45	+0.075 +0.050	55	+0.060 +0.041	70	0 -0.3	5	0 -0.1								
50	+0.075 +0.050	60	+0.060 +0.041	75	0 -0.3	5	0 -0.1								
55	+0.090 +0.060	65	+0.060 +0.041	80	0 -0.3	5	0 -0.1								
60	+0.090 +0.060	75	+0.062 +0.043	90	0 -0.3	7.5	0 -0.1								
63	+0.090 +0.060	75	+0.062 +0.043	85	0 -0.3	7.5	0 -0.1								
65	+0.090 +0.060	80	+0.062 +0.043	95	0 -0.3	7.5	0 -0.1								
70	+0.090 +0.060	85	+0.073 +0.051	105	0 -0.3	7.5	0 -0.1								
75	+0.090 +0.060	90	+0.073 +0.051	110	0 -0.3	7.5	0 -0.1								
80	+0.090 +0.060	100	+0.073 +0.051	120	0 -0.3	10	0 -0.1								
90	+0.107 +0.072	110	+0.076 +0.054	130	0 -0.3	10	0 -0.1								
100	+0.107 +0.072	120	+0.076 +0.054	150	0 -0.3	10	0 -0.1								
120	+0.107 +0.072	140	+0.088 +0.063	170	0 -0.3	10	0 -0.1								
130	+0.125 +0.085	150	+0.090 +0.065	180	0 -0.3	10	0 -0.1								
140	+0.125 +0.085	160	+0.090 +0.065	190	0 -0.3	10	0 -0.1								
150	+0.125 +0.085	170	+0.093 +0.068	200	0 -0.3	10	0 -0.1								
160	+0.125 +0.085	180	+0.093 +0.068	210	0 -0.3	10	0 -0.1								

※Part No. with * are made-to-order.
 ※The I.D. tolerance after press fitting is for reference only. ▲ The dimensional tolerances are the values measured at +25°C.

Length L Tolerance -0.1 -0.3										I.D. tolerance after press fitting (reference)	I.D. phi d
30	35	40	50	60	67.5	80	100	120			
										+0.016 +0.004	6
										+0.021 +0.006	8
										+0.021 +0.006	10
1230										+0.031 +0.013	12
1330										+0.026 +0.008	13
										+0.026 +0.008	14
1530										+0.026 +0.008	15
1630	1635	1640								+0.026 +0.008	16
1830	1835	1840								+0.026 +0.008	18
2030	2035	2040								+0.037 +0.016	20
2530	2535	2540	2550							+0.032 +0.011	25
3030	3035	3040	3050							+0.032 +0.011	30
3130	3135	3140								+0.046 +0.021	31.5
3530	3535	3540	3550							+0.046 +0.021	35
4030	4035	4040	4050							+0.046 +0.021	40
4530	4535	4540	4550	4560						+0.040 +0.015	45
5030	5035	5040	5050	5060						+0.040 +0.015	50
		5540		5560						+0.055 +0.025	55
		★6040	★6050	6060		★6080				+0.053 +0.023	60
						★6367				+0.053 +0.023	63
					6560					+0.053 +0.023	65
			7050			7080				+0.046 +0.016	70
				7560						+0.046 +0.016	75
				8060		8080	80100			+0.046 +0.016	80
				9060		9080				+0.060 +0.025	90
						10080	100100			+0.060 +0.025	100
						12080	120100			+0.052 +0.017	120
							*13080	*130100		+0.068 +0.028	130
							*14080	*140100		+0.068 +0.028	140
								*150100	*150120	+0.065 +0.025	150
								*160100	*160120	+0.065 +0.025	160

SPFG Oiles 500SP1 SL1 Thrust Bushings

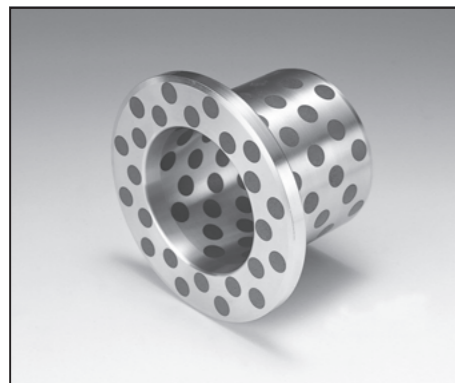

Specify Part No. by required I.D. and Length.
(e.g.) I.D. is 35mm and length is 25mm.

SPFG - 3525

Part No.

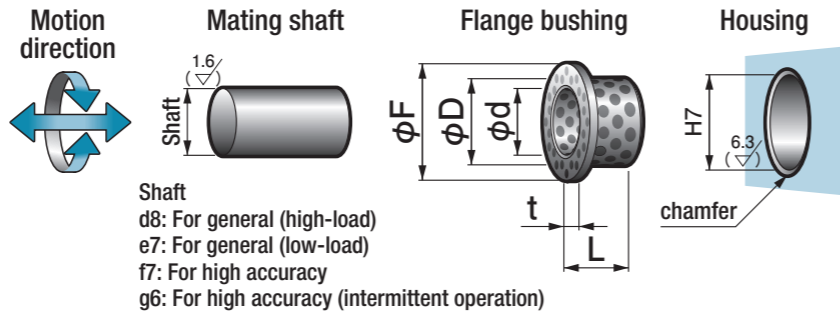

Shaft
d8: For general (high-load)
e7: For general (low-load)
f7: For high accuracy
g6: For high accuracy (intermittent operation)

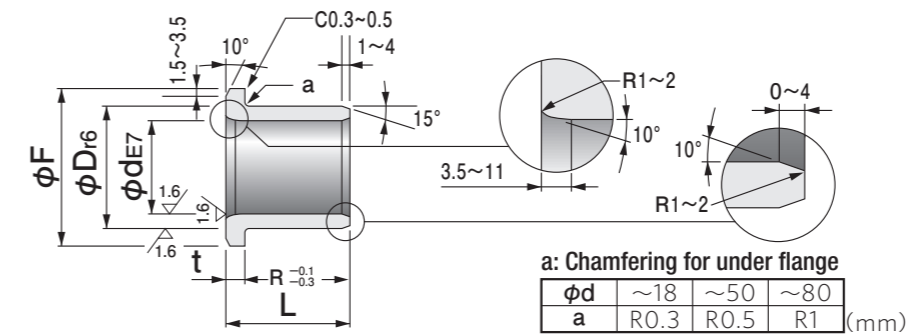

a: Chamfering for under flange

- Applicable to rotational, oscillating, and reciprocating motion.
- This bushing can be subject to both radial-journal and thrust load.
- Improve machining by more accurate flange thickness.

I.D.		O.D.		Flange				Length L					
φd	Tolerance	φD	Tolerance	φF	Tolerance	t	Tolerance	11	13	18	20	23	25
6	+0.032 +0.020	10	+0.028 +0.019	20	0 -0.3	3	0 -0.03	0611					
8	+0.040 +0.025	12	+0.034 +0.023	25	0 -0.3	3	0 -0.03		0813				
10	+0.040 +0.025	14	+0.034 +0.023	25	0 -0.3	3	0 -0.03		1013	1018			
12	+0.050 +0.032	18	+0.034 +0.023	30	0 -0.3	3	0 -0.03	1211		1218		1223	
13	+0.050 +0.032	19	+0.041 +0.028	30	0 -0.3	3	0 -0.03		1313	1318		1323	
15	+0.050 +0.032	21	+0.041 +0.028	35	0 -0.3	3	0 -0.03		1513	1518		1523	
16	+0.050 +0.032	22	+0.041 +0.028	35	0 -0.3	3	0 -0.03		1613	1618		1623	
18	+0.050 +0.032	24	+0.041 +0.028	40	0 -0.3	3	0 -0.03			1818		1823	
20	+0.061 +0.040	28	+0.041 +0.028	45	0 -0.3	5	0 -0.03				2020		2025
25	+0.061 +0.040	33	+0.050 +0.034	50	0 -0.3	5	0 -0.03				2520		2525
30	+0.061 +0.040	38	+0.050 +0.034	55	0 -0.3	5	0 -0.03				3020		3025
35	+0.075 +0.050	44	+0.050 +0.034	65	0 -0.3	5	0 -0.03				3520		3525
40	+0.075 +0.050	50	+0.050 +0.034	70	0 -0.3	7	0 -0.03						
50	+0.075 +0.050	62	+0.060 +0.041	90	0 -0.3	8	0 -0.04						
60	+0.090 +0.060	74	+0.062 +0.043	110	0 -0.3	8	0 -0.04						
70	+0.090 +0.060	85	+0.073 +0.051	120	0 -0.3	10	0 -0.04						
80	+0.090 +0.060	96	+0.073 +0.051	140	0 -0.3	10	0 -0.04						

※The I.D. tolerance after press fitting is for reference only.

▲The dimensional tolerances are the values measured at +25°C.

Length L												I.D. tolerance after press fitting (reference)	I.D. φd
27	35	37	38	47	48	50	58	60	68	80	90		
												+0.016 +0.004	6
												+0.021 +0.006	8
												+0.021 +0.006	10
												+0.031 +0.013	12
												+0.026 +0.008	13
												+0.026 +0.008	15
												+0.026 +0.008	16
												+0.026 +0.008	18
												+0.037 +0.016	20
												+0.032 +0.011	25
	3035											+0.032 +0.011	30
	3535											+0.046 +0.021	35
4027		4037		4047								+0.046 +0.021	40
				5038		5048		5058				+0.040 +0.015	50
				6038		6048		6058		6068		+0.053 +0.023	60
								7050			7080	+0.046 +0.016	70
										8060		+0.046 +0.016	80

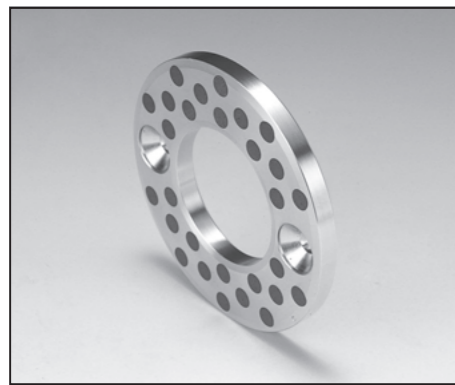

Specify Part No. by required I.D. and thickness.
(e.g.) I.D. is 30.2mm and thickness is 5mm.

SPW - 3005
Part No.

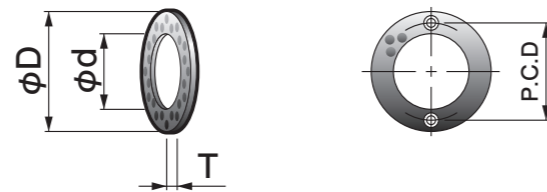

- May be combined with the SPB.
- See the description of the SPB for combination. (Pages 187 to 190)
- The products with the N marks at the end of the part numbers have no mounting holes.

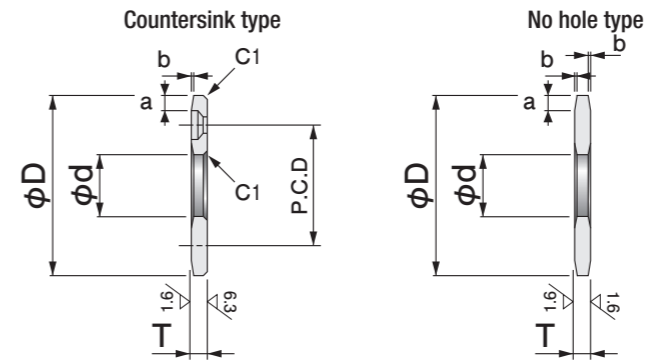

a b: Chamfering for I.D. and O.D.

φd	~10.2	~18.2	~35.2	~45.2	~55.3	~100.5	120.5
a	1.5	2	2.5	3	4	5	4
b	0.3	0.4	0.4	0.5	0.6	0.8	0.8

(mm)

Part No.	I.D.		O.D.	Thickness		Mounting hole		
	φd	Tolerance		φD	T	Tolerance	P.C.D.	No. of holes
SPW-0603	6.2	+0.2 +0.1	25	3	0 -0.1	15	2	M3
SPW-0803	8.2	+0.2 +0.1	28	3	0 -0.1	18	2	M3
SPW-1003	10.2	+0.2 +0.1	30	3	0 -0.1	20	2	M3
SPW-1203	12.2	+0.2 +0.1	40	3	0 -0.1	28	2	M3
SPW-1203N	12.2	+0.2 +0.1	40	3	0 -0.1	no hole		
SPW-1303	13.2	+0.2 +0.1	40	3	0 -0.1	28	2	M3
SPW-1403	14.2	+0.2 +0.1	40	3	0 -0.1	28	2	M3
SPW-1503	15.2	+0.2 +0.1	50	3	0 -0.1	35	2	M3
SPW-1603	16.2	+0.2 +0.1	50	3	0 -0.1	35	2	M3
SPW-1603N	16.2	+0.2 +0.1	50	3	0 -0.1	no hole		
SPW-1803	18.2	+0.2 +0.1	50	3	0 -0.1	35	2	M3
SPW-2005	20.2	+0.2 +0.1	50	5	0 -0.1	35	2	M5
SPW-2505	25.2	+0.2 +0.1	55	5	0 -0.1	40	2	M5
SPW-2505N	25.2	+0.2 +0.1	55	5	0 -0.1	no hole		
SPW-3005	30.2	+0.2 +0.1	60	5	0 -0.1	45	2	M5
SPW-3005N	30.2	+0.2 +0.1	60	5	0 -0.1	no hole		
SPW-3505	35.2	+0.2 +0.1	70	5	0 -0.1	50	2	M5

Part No.	I.D.		O.D.	Thickness		Mounting hole		
	φd	Tolerance		φD	T	Tolerance	P.C.D.	No. of holes
SPW-4007	40.2	+0.2 +0.1	80	7	0 -0.1	60	2	M6
SPW-4507	45.2	+0.2 +0.1	90	7	0 -0.1	70	2	M6
SPW-5008	50.3	+0.3 +0.1	100	8	0 -0.1	75	4	M6
SPW-5508	55.3	+0.3 +0.1	110	8	0 -0.1	85	4	M6
SPW-6008	60.3	+0.3 +0.1	120	8	0 -0.1	90	4	M8
SPW-6508	65.3	+0.3 +0.1	125	8	0 -0.1	95	4	M8
SPW-7010	70.3	+0.3 +0.1	130	10	0 -0.1	100	4	M8
SPW-7510	75.3	+0.3 +0.1	140	10	0 -0.1	110	4	M8
SPW-8010	80.3	+0.3 +0.1	150	10	0 -0.1	120	4	M8
SPW-9010	90.5	+0.3 +0.1	170	10	0 -0.1	140	4	M10
SPW-10010	100.5	+0.3 +0.1	190	10	0 -0.1	160	4	M10
SPW-12010	120.5	+0.3 +0.1	200	10	0 -0.1	175	4	M10

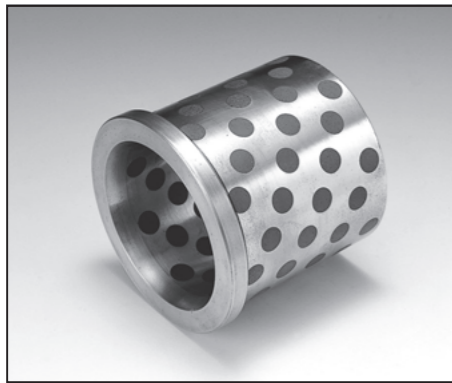

Specify Part No. by required I.D., O.D. and Length.
(e.g.) I.D. is 65mm, O.D. is 80mm, and length is 80mm.

SGF - 658080
Part No.

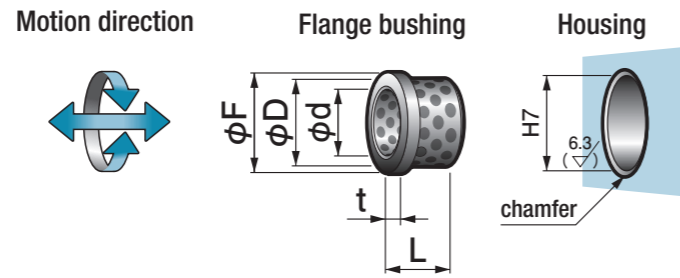

- Applicable to rotation, oscillation, and reciprocating motion.
- It is recommended to use a set screw to prevent dislocation.

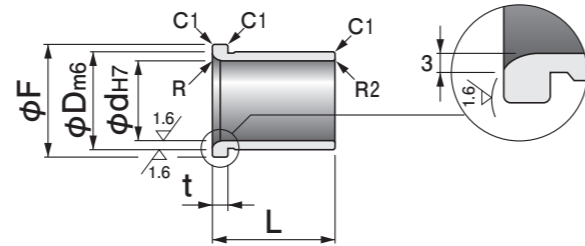

Part No.	I.D.		O.D.		Flange		Length		R
	ϕd	Tolerance	ϕD	Tolerance	ϕF	t	L	Tolerance	
SGF-253540	25	$^{+0.021}_0$	35	$^{+0.025}_{+0.009}$	45	7	40	$^0_{-0.3}$	10
SGF-304050	30	$^{+0.021}_0$	40	$^{+0.025}_{+0.009}$	50	10	50	$^0_{-0.3}$	20
SGF-405570	40	$^{+0.025}_0$	55	$^{+0.030}_{+0.011}$	65	10	70	$^0_{-0.3}$	20
SGF-506580	50	$^{+0.025}_0$	65	$^{+0.030}_{+0.011}$	75	10	80	$^0_{-0.3}$	20
SGF-607580	60	$^{+0.030}_0$	75	$^{+0.030}_{+0.011}$	85	10	80	$^0_{-0.3}$	20
SGF-658080	65	$^{+0.030}_0$	80	$^{+0.030}_{+0.011}$	90	10	80	$^0_{-0.3}$	20
SGF-6580120	65	$^{+0.030}_0$	80	$^{+0.030}_{+0.011}$	90	10	120	$^0_{-0.3}$	20
SGF-80100100	80	$^{+0.030}_0$	100	$^{+0.035}_{+0.013}$	110	10	100	$^0_{-0.3}$	20
SGF-80100140	80	$^{+0.030}_0$	100	$^{+0.035}_{+0.013}$	110	10	140	$^0_{-0.3}$	20
SGF-100120100	100	$^{+0.035}_0$	120	$^{+0.035}_{+0.013}$	130	10	100	$^0_{-0.3}$	20
SGF-100120140	100	$^{+0.035}_0$	120	$^{+0.035}_{+0.013}$	130	10	140	$^0_{-0.3}$	20

▲ The dimensional tolerances are the values measured at +25°C.

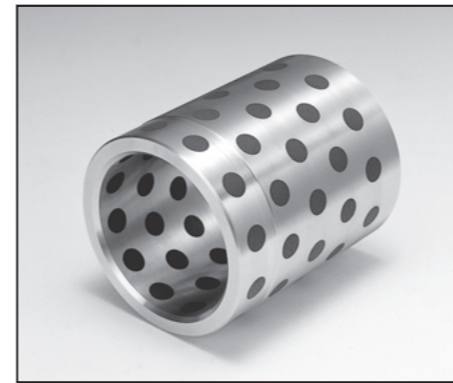

Specify Part No. by required I.D., O.D. and Length.
(e.g.) I.D. is 60mm, O.D. is 80mm, and length is 90mm.

SGB - 608090
Part No.

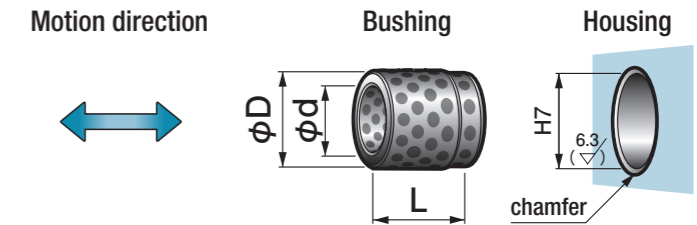

- Applicable to reciprocating motion.
- It is recommended to use a set screw to prevent dislocation.

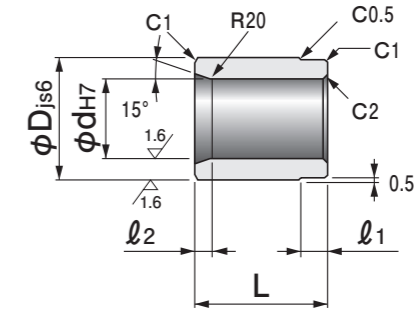

Part No.	I.D.		O.D.		Length		l_1	l_2
	ϕd	Tolerance	ϕD	Tolerance	L	Tolerance		
SGB-254040	25	$^{+0.021}_0$	40	± 0.008	40	$^0_{-0.2}$	10	5
SGB-305050	30	$^{+0.021}_0$	50	± 0.008	50	$^0_{-0.2}$	10	5
SGB-356055	35	$^{+0.025}_0$	60	± 0.0095	55	$^0_{-0.2}$	15	5
SGB-406060	40	$^{+0.025}_0$	60	± 0.0095	60	$^0_{-0.2}$	10	5
SGB-507075	50	$^{+0.025}_0$	70	± 0.0095	75	$^0_{-0.2}$	15	10
SGB-608090	60	$^{+0.030}_0$	80	± 0.0095	90	$^0_{-0.2}$	20	10
SGB-80100120	80	$^{+0.030}_0$	100	± 0.011	120	$^0_{-0.2}$	25	10
SGB-100120150	100	$^{+0.035}_0$	120	± 0.011	150	$^0_{-0.2}$	25	10
SGB-120140180	120	$^{+0.035}_0$	140	± 0.0125	180	$^0_{-0.2}$	25	10

▲ The dimensional tolerances are the values measured at +25°C.

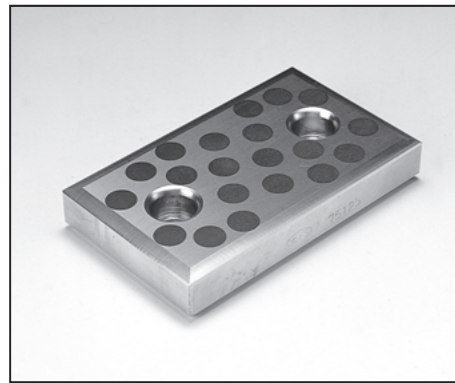

Specify Part No. by required width and length.

(e.g.) Width is 75mm and length is 200mm. **SWP - 75200**

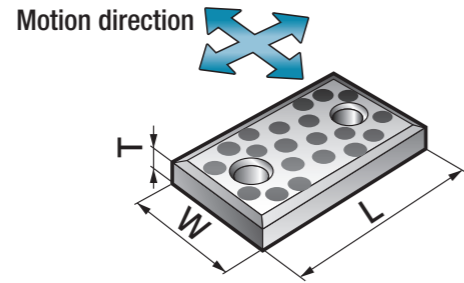

Part No.

● Motion direction: width and length direction

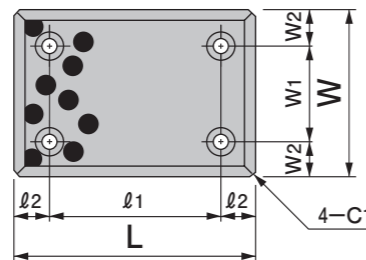
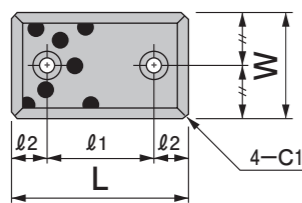

Cross-section

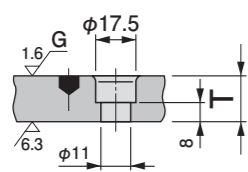

Chamfering

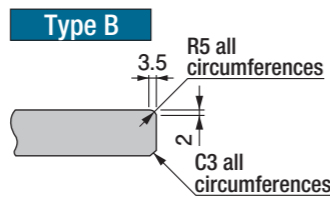
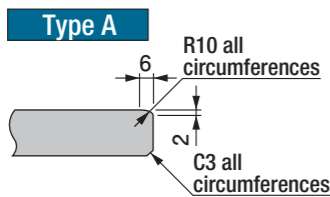

Example of combination use with SLP.

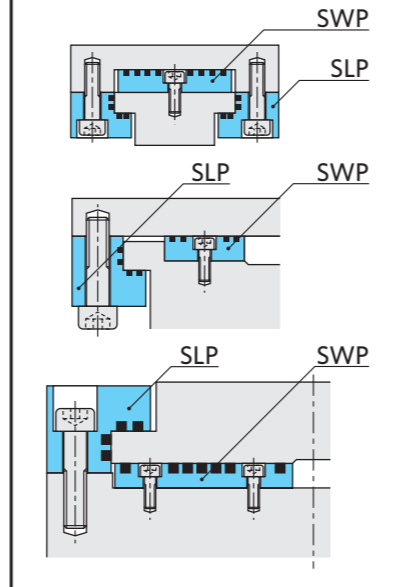

Part No.	Width		Length		Thickness		Mounting hole intervals					Attach bolts		Chamfering	
	W	Tolerance	L	Tolerance	T	Tolerance	W1	Tolerance	W2	l1	Tolerance	l2	Type		Qty
SWP-4875	48	-0.1 -0.3	75	-0.1 -0.3	20	± 0.025	—	—	—	45	± 0.2	15	M10 Hexagon socket head	2	B
SWP-48100	48	-0.1 -0.3	100	-0.1 -0.3	20	± 0.025	—	—	—	50	± 0.2	25	M10 Hexagon socket head	2	B
SWP-48125	48	-0.1 -0.3	125	-0.1 -0.3	20	± 0.025	—	—	—	75	± 0.2	25	M10 Hexagon socket head	2	B
SWP-48150	48	-0.1 -0.3	150	-0.1 -0.3	20	± 0.025	—	—	—	100	± 0.2	25	M10 Hexagon socket head	2	B
SWP-7575B	75	-0.1 -0.3	75	-0.1 -0.3	20	± 0.025	—	—	—	25	± 0.2	25	M10 Hexagon socket head	2	A
SWP-75100B	75	-0.1 -0.3	100	-0.1 -0.3	20	± 0.025	—	—	—	50	± 0.2	25	M10 Hexagon socket head	2	A
SWP-75125	75	-0.1 -0.3	125	-0.1 -0.3	20	± 0.025	—	—	—	75	± 0.2	25	M10 Hexagon socket head	2	A
SWP-75150	75	-0.1 -0.3	150	-0.1 -0.3	20	± 0.025	—	—	—	100	± 0.2	25	M10 Hexagon socket head	2	A
SWP-75200	75	-0.1 -0.3	200	-0.1 -0.3	20	± 0.025	—	—	—	150	± 0.2	25	M10 Hexagon socket head	2	A
SWP-100100	100	-0.1 -0.3	100	-0.1 -0.3	20	± 0.025	50	± 0.2	25	50	± 0.2	25	M10 Hexagon socket head	4	A
SWP-100125	100	-0.1 -0.3	125	-0.1 -0.3	20	± 0.025	50	± 0.2	25	75	± 0.2	25	M10 Hexagon socket head	4	A
SWP-100150	100	-0.1 -0.3	150	-0.1 -0.3	20	± 0.025	50	± 0.2	25	100	± 0.2	25	M10 Hexagon socket head	4	A
SWP-100200	100	-0.1 -0.3	200	-0.1 -0.3	20	± 0.025	50	± 0.2	25	150	± 0.2	25	M10 Hexagon socket head	4	A
SWP-100250	100	-0.1 -0.3	250	-0.1 -0.3	20	± 0.025	50	± 0.2	25	200	± 0.2	25	M10 Hexagon socket head	4	A
SWP-125150	125	-0.1 -0.3	150	-0.1 -0.3	20	± 0.025	50	± 0.2	37.5	100	± 0.2	25	M10 Hexagon socket head	4	A
SWP-125200	125	-0.1 -0.3	200	-0.1 -0.3	20	± 0.025	50	± 0.2	37.5	150	± 0.2	25	M10 Hexagon socket head	4	A
SWP-125250	125	-0.1 -0.3	250	-0.1 -0.3	20	± 0.025	50	± 0.2	37.5	200	± 0.2	25	M10 Hexagon socket head	4	A
SWP-150150	150	-0.1 -0.3	150	-0.1 -0.3	20	± 0.025	100	± 0.2	25	100	± 0.2	25	M10 Hexagon socket head	4	A
SWP-150200	150	-0.1 -0.3	200	-0.1 -0.3	20	± 0.025	100	± 0.2	25	150	± 0.2	25	M10 Hexagon socket head	4	A
SWP-150250	150	-0.1 -0.3	250	-0.1 -0.3	20	± 0.025	100	± 0.2	25	200	± 0.2	25	M10 Hexagon socket head	4	A



Specify Part No. by required width and length.
 (e.g.) Width is 28mm and length is 150mm. **SFP - 28150**
Part No.

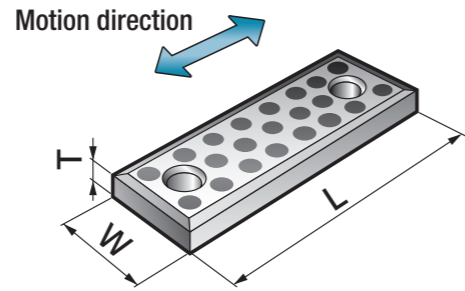

● Motion direction: length direction

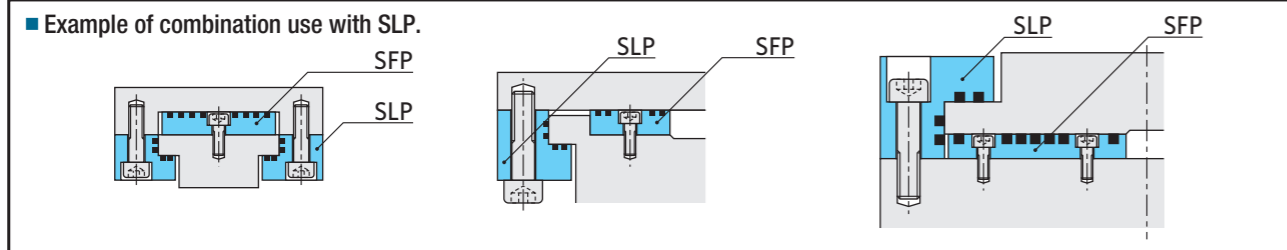

W=18, 28, 38, 48

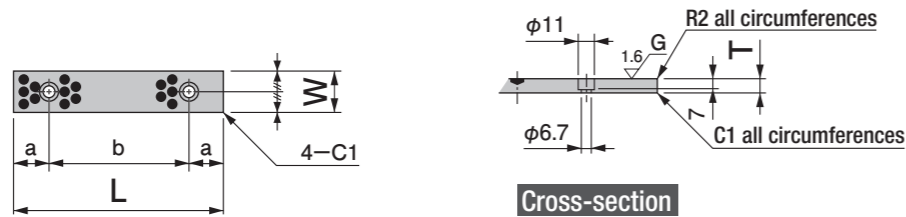

Part No.	Width		Length	Thickness	Hole intervals		Attach bolts	
	W	L			T	Tolerance	a	b
SFP-1875	18	75	10	+0.04 +0.01	15	45	M6 Hexagon socket head	2
SFP-18100	18	100	10	+0.04 +0.01	25	50	M6 Hexagon socket head	2
SFP-18125	18	125	10	+0.04 +0.01	25	75	M6 Hexagon socket head	2
SFP-18150	18	150	10	+0.04 +0.01	25	100	M6 Hexagon socket head	2
SFP-2875	28	75	10	+0.04 +0.01	15	45	M6 Hexagon socket head	2
SFP-28100	28	100	10	+0.04 +0.01	25	50	M6 Hexagon socket head	2
SFP-28125	28	125	10	+0.04 +0.01	25	75	M6 Hexagon socket head	2
SFP-28150	28	150	10	+0.04 +0.01	25	100	M6 Hexagon socket head	2
SFP-3875	38	75	10	+0.04 +0.01	15	45	M6 Hexagon socket head	2
SFP-38100	38	100	10	+0.04 +0.01	25	50	M6 Hexagon socket head	2
SFP-38125	38	125	10	+0.04 +0.01	25	75	M6 Hexagon socket head	2
SFP-38150	38	150	10	+0.04 +0.01	25	100	M6 Hexagon socket head	2
SFP-4875	48	75	10	+0.04 +0.01	15	45	M6 Hexagon socket head	2
SFP-48100	48	100	10	+0.04 +0.01	25	50	M6 Hexagon socket head	2
SFP-48125	48	125	10	+0.04 +0.01	25	75	M6 Hexagon socket head	2
SFP-48150	48	150	10	+0.04 +0.01	25	100	M6 Hexagon socket head	2

W=35, 50

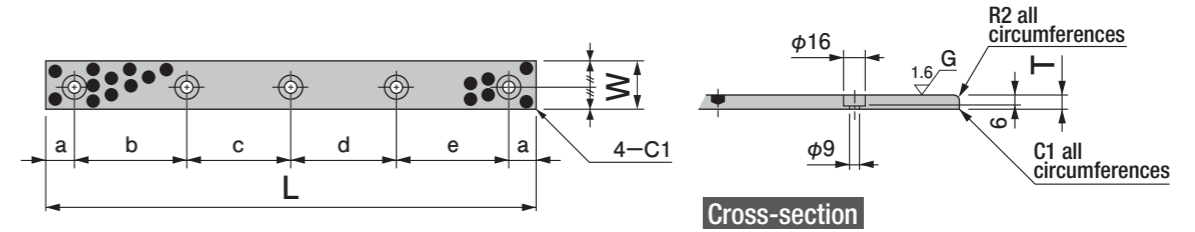

Part No.	Width		Length	Thickness	Hole intervals					Attach bolts	
	W	L			T	Tolerance	a	b	c	d	e
SFP-35100	35	100	10	±0.025	20	60	—	—	—	M8 Flat head	2
SFP-35150	35	150	10	±0.025	20	55	55	—	—	M8 Flat head	3
SFP-35200	35	200	10	±0.025	20	55	50	55	—	M8 Flat head	4
SFP-35250	35	250	10	±0.025	20	70	70	70	—	M8 Flat head	4
SFP-35300	35	300	10	±0.025	20	65	65	65	65	M8 Flat head	5
SFP-35350	35	350	10	±0.025	20	80	75	75	80	M8 Flat head	5
SFP-50100	50	100	10	±0.025	20	60	—	—	—	M8 Flat head	2
SFP-50150	50	150	10	±0.025	20	55	55	—	—	M8 Flat head	3
SFP-50200	50	200	10	±0.025	20	55	50	55	—	M8 Flat head	4
SFP-50250	50	250	10	±0.025	20	70	70	70	—	M8 Flat head	4
SFP-50300	50	300	10	±0.025	20	65	65	65	65	M8 Flat head	5
SFP-50400	50	400	10	±0.025	20	90	90	90	90	M8 Flat head	5

W=75

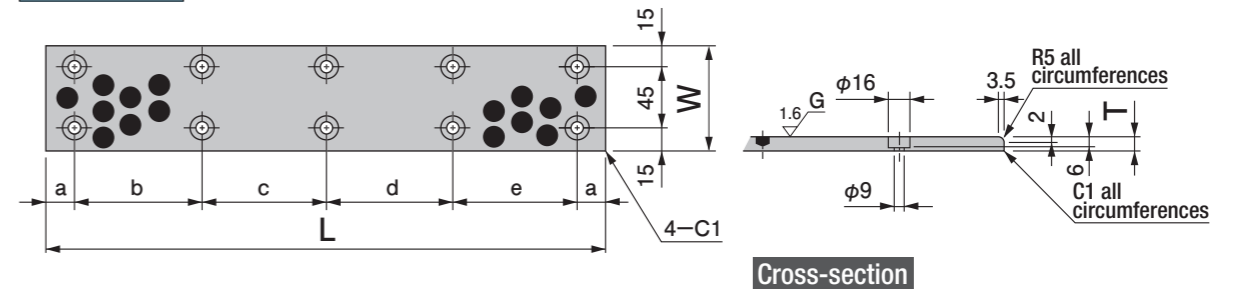

Part No.	Width		Length	Thickness	Hole intervals					Attach bolts	
	W	L			T	Tolerance	a	b	c	d	e
SFP-75150	75	150	10	±0.025	20	110	—	—	—	M8 Flat head	4
SFP-75200	75	200	10	±0.025	20	80	80	—	—	M8 Flat head	6
SFP-75250	75	250	10	±0.025	20	105	105	—	—	M8 Flat head	6
SFP-75300	75	300	10	±0.025	20	85	90	85	—	M8 Flat head	8
SFP-75400	75	400	10	±0.025	20	120	120	120	—	M8 Flat head	8
SFP-75500	75	500	10	±0.025	20	115	115	115	115	M8 Flat head	10



Specify Part No. by required width and length.
(e.g.) Width is 50mm and length is 300mm.

SLP - 50300A
Part No.

Motion direction

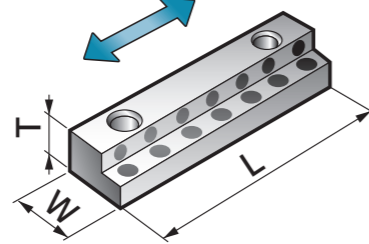

● Motion direction: length direction

■ Example of combination use with SWP or SFP.

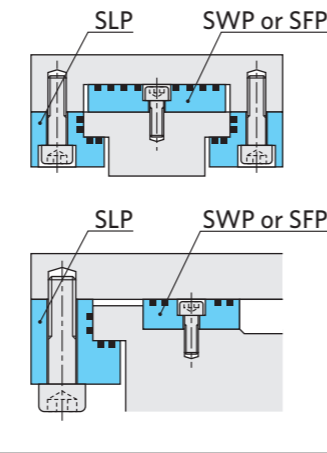

● Hexagonal socket head bolts are fitted.

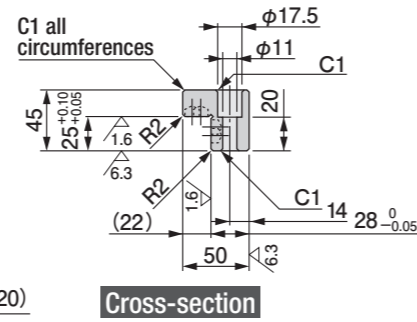
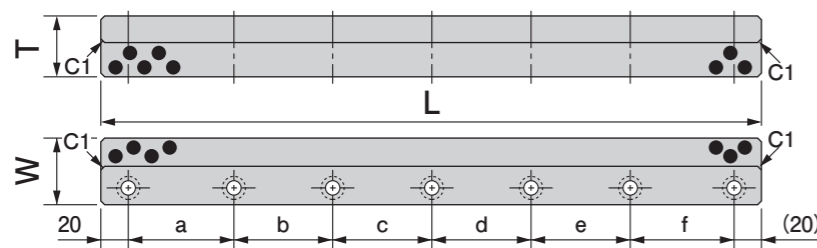

Part No.	Width		Length	Thickness	Hole intervals					Attach bolts	
	W	L			T	a	b	c	d	e	f
SLP-50200A	50	200	45	55	50	55	—	—	—	M10 Hexagon socket head	4
SLP-50250A	50	250	45	70	70	70	—	—	—	M10 Hexagon socket head	4
SLP-50300A	50	300	45	65	65	65	65	—	—	M10 Hexagon socket head	5
SLP-50350A	50	350	45	80	75	75	80	—	—	M10 Hexagon socket head	5
SLP-50500A	50	500	45	80	75	75	75	75	80	M10 Hexagon socket head	7

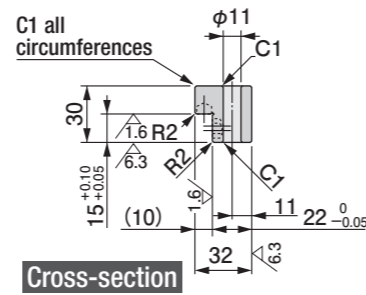
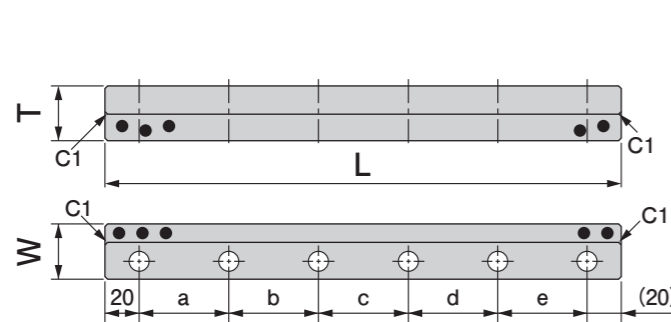

Part No.	Width		Length	Thickness	Hole intervals					Attach bolts	
	W	L			T	a	b	c	d	e	Type
SLP-32100B	32	100	30	60	—	—	—	—	—	M10	2
SLP-32150B	32	150	30	55	55	—	—	—	—	M10	3
SLP-32200B	32	200	30	55	50	55	—	—	—	M10	4
SLP-32250B	32	250	30	70	70	70	—	—	—	M10	4
SLP-32400B	32	400	30	75	70	70	70	75	—	M10	6

● Hexagonal socket head bolts are fitted.

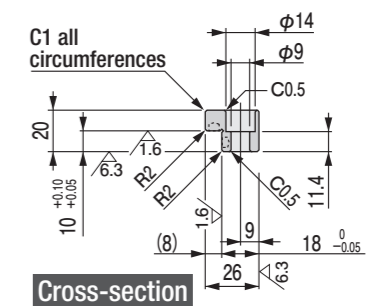
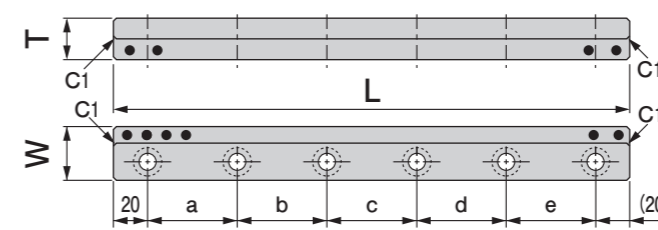

Part No.	Width		Length	Thickness	Hole intervals					Attach bolts	
	W	L			T	a	b	c	d	e	Type
SLP-26100C	26	100	20	60	—	—	—	—	—	M8 Hexagon socket head	2
SLP-26150C	26	150	20	55	55	—	—	—	—	M8 Hexagon socket head	3
SLP-26200C	26	200	20	55	50	55	—	—	—	M8 Hexagon socket head	4
SLP-26400C	26	400	20	75	70	70	70	75	—	M8 Hexagon socket head	6

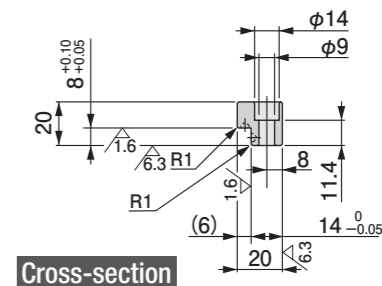
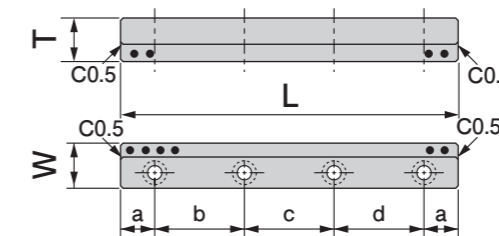

Part No.	Width		Length	Thickness	Hole intervals				Attach bolts	
	W	L			T	a	b	c	d	Type
SLP-2050	20	50	20	10	30	—	—	—	M8 Hexagon socket head	2
SLP-20100	20	100	20	20	60	—	—	—	M8 Hexagon socket head	2
SLP-20150	20	150	20	20	55	55	—	—	M8 Hexagon socket head	3
SLP-20200	20	200	20	20	55	50	55	—	M8 Hexagon socket head	4

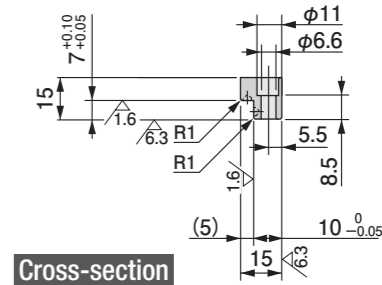
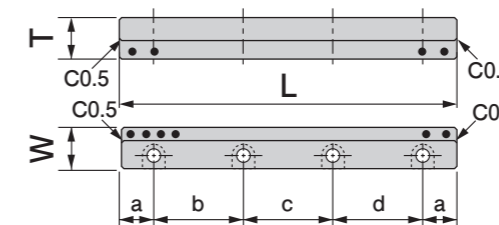

Part No.	Width		Length	Thickness	Hole intervals				Attach bolts	
	W	L			T	a	b	c	d	Type
SLP-1550	15	50	15	10	30	—	—	—	M6 Hexagon socket head	2
SLP-15100	15	100	15	20	60	—	—	—	M6 Hexagon socket head	2
SLP-15150	15	150	15	20	55	55	—	—	M6 Hexagon socket head	3
SLP-15200	15	200	15	20	55	50	55	—	M6 Hexagon socket head	4

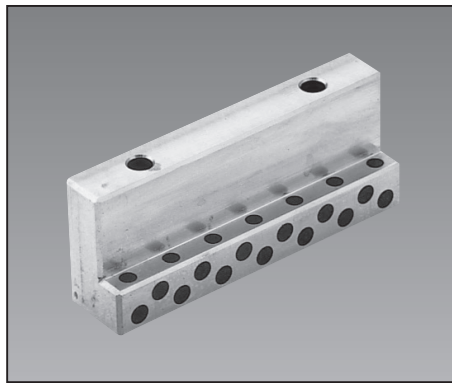

Specify Part No. by required thickness and length.
(e.g.) Thickness is 20mm and length is 100mm.

SLC - 41100
Part No.

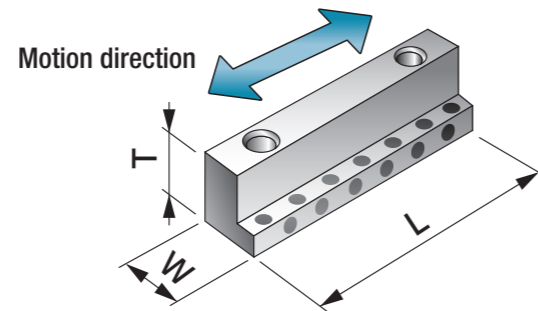

● Motion direction: length direction

■ Example of attachment.

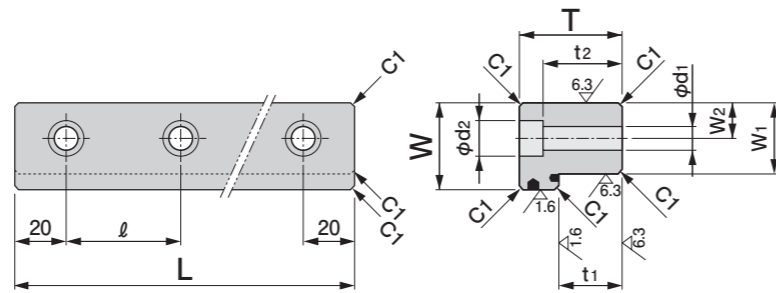
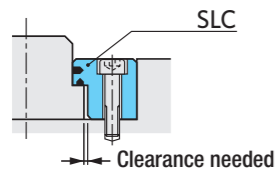

Part No.	Thickness		Length		Width				Attach bolts						
	T	L	W	Tolerance	t ₁	Tolerance	W ₁	Tolerance	ℓ	W ₂	φd ₁	φd ₂	t ₂	Type	Qty
SLC-30100	30	100	23	-0.01 -0.05	15	+0.05 +0.02	15	0 -0.05	60	7.5	7	11	23	M6 Hexagon socket head	2
SLC-30130	30	130	23	-0.01 -0.05	15	+0.05 +0.02	15	0 -0.05	90	7.5	7	11	23	M6 Hexagon socket head	2
SLC-30160	30	160	23	-0.01 -0.05	15	+0.05 +0.02	15	0 -0.05	60	7.5	7	11	23	M6 Hexagon socket head	3
SLC-30220	30	220	23	-0.01 -0.05	15	+0.05 +0.02	15	0 -0.05	60	7.5	7	11	23	M6 Hexagon socket head	4
SLC-41100	41	100	23	-0.01 -0.05	26	+0.05 +0.02	15	0 -0.05	60	7.5	7	11	34	M6 Hexagon socket head	2
SLC-41130	41	130	23	-0.01 -0.05	26	+0.05 +0.02	15	0 -0.05	90	7.5	7	11	34	M6 Hexagon socket head	2
SLC-41160	41	160	23	-0.01 -0.05	26	+0.05 +0.02	15	0 -0.05	60	7.5	7	11	34	M6 Hexagon socket head	3
SLC-41220	41	220	23	-0.01 -0.05	26	+0.05 +0.02	15	0 -0.05	60	7.5	7	11	34	M6 Hexagon socket head	4
SLC-56100	56	100	28	-0.01 -0.05	26	+0.05 +0.02	20	0 -0.05	60	10	9	14	47	M8 Hexagon socket head	2
SLC-56160	56	160	28	-0.01 -0.05	26	+0.05 +0.02	20	0 -0.05	60	10	9	14	47	M8 Hexagon socket head	3
SLC-56220	56	220	28	-0.01 -0.05	26	+0.05 +0.02	20	0 -0.05	60	10	9	14	47	M8 Hexagon socket head	4



Specify Part No. by required thickness and length.
(e.g.) Thickness is 20mm.

SLI - 20300
Part No.

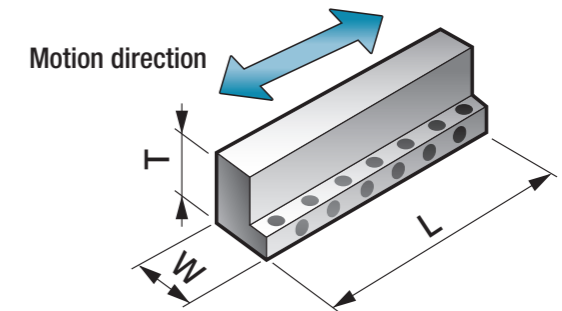

- This slide guide rail may be cut to the necessary dimension or bored for bolts.
- The movement direction is lengthwise.

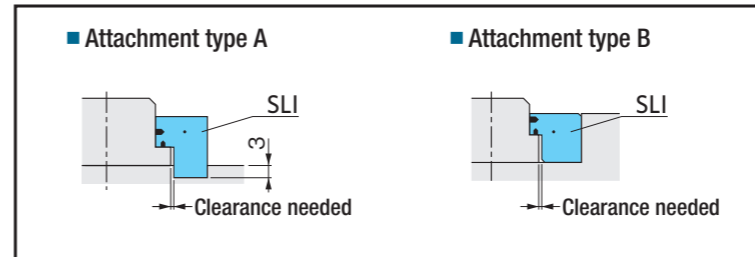
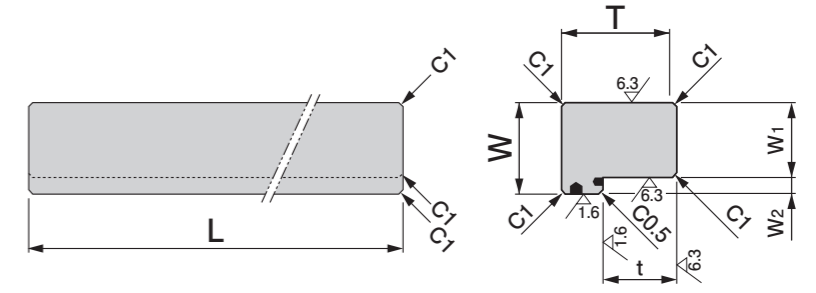

Part No.	Thickness		Length		Width		Attachment			
	T	L	W	Tolerance	t	Tolerance	W ₁	Tolerance	W ₂	Attachment type
SLI-20300	20	300	15	-0.01 -0.05	11	+0.05 +0.02	10	0 -0.05	5	A
SLI-25300	25	300	23	-0.01 -0.05	10	+0.05 +0.02	15	0 -0.05	8	B

Selection Guide
Product Information
Plastic Bearing
Multi-layer Bearing
Metallic Bearing
Air Bearings
Slide Shifter
Technical Information
Corporate Profile

Selection Guide
Product Information
Plastic Bearing
Multi-layer Bearing
Metallic Bearing
Air Bearings
Slide Shifter
Technical Information
Corporate Profile