

Oiles 80 Oil-impregnated polyacetal bearings

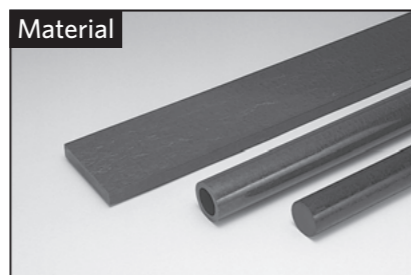

Feature

- Serviceable without the need for lubrication.
- Has superior load resistance and wear resistance.
- Features low coefficient of friction and superior speed characteristics.
- Prevents stick slips and squeak noises.
- Injection-molded and can be made in complicated shapes. Good mass productivity.
- Standard products and materials for machining are available in various sizes.
- For a low volatile organic compound type, Oiles 80-LVF is available on order.

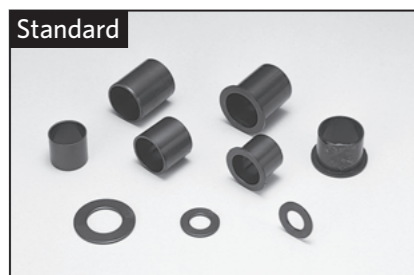
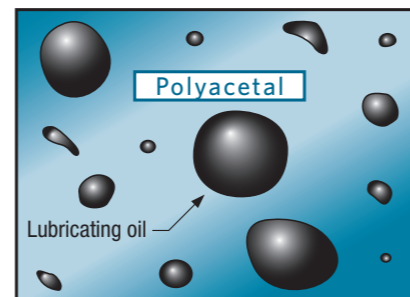

Image

Service range

Lubrication condition	Dry
Service temperature range °C	-40~+80
Allowable max. pressure P N/mm ² [kgf/cm ²]	17.5 {179}
Allowable max. velocity V m/s [m/min]	0.85 {51}
Allowable max. PV value N/mm ² · m/s [kgf/cm ² · m/min]	2.45 {1,500}

※ These are values of the typical grade Oiles 80.

Mechanical properties

Specific gravity	ASTM D 792	—	1.39
Tensile strength	ASTM D 638	N/mm ² [kgf/cm ²]	51.0 {520}
Tensile elongation at break	ASTM D 638	%	60
Flexural property	ASTM D 790	N/mm ² [kgf/cm ²]	76.5 {780}
Flexural modulus	ASTM D 790	N/mm ² [kgf/cm ²]	2,650 {27,000}
Compressive stress	ASTM D 695	N/mm ² [kgf/cm ²]	1% deformation
			10% deformation
Hardness	ASTM D 785	HRM	72
Izod impact strength (with notch)	ASTM D 256	J/m [kgfcm/cm]	58.8 {6.00}
Co-efficient of linear expansion	ASTM D 696	×10 ⁻⁵ °C ⁻¹	8~13
Deflection temperature under load 1.82 MPa	ASTM D 648	°C	110
Melting point	DSC	°C	165
UL incombustibility	UL94	File No.E78113	HB (Note)

※ The values shown above are typical values, not the standard values.
(Note) Excludes 80M, 80P, 80S and 80-LVF.

Lathe turning

		carbide tool (JIS)	
Cutting tool	Relief angle	5~10°	
	Rake angle	10~20°	
	Nose radius (mm)	0.20~0.40	
Condition	Speed (m/min)	100~250	
	Cut depth (mm)	0.10~0.50	
	Feed (mm/rev)	0.05~0.20	

Attention should be paid to dimensional variances due to thermal expansion, chucking, and bend of the material.

※ Contact us for grinding and milling information.

Machining accuracy (bushing)

I.D.	O.D.	Length
class 8 to 9	class 7 to 8	class 9 to 10

Classes here are in JIS standard.

This product demonstrates satisfactory performance at the slide surface roughness of Rz6.3 to 12.5μm.

Dimensions may change due to thermal expansion, chucking pressure, moisture absorption deformation, etc. High accuracy is ensured if the product is installed on the housing and then ground.

Test data

Journal rotation test

<Testing conditions>
Bearing dimension : φ35×φ38×ℓ20
Pressure : 0.39N/mm²{4.0kgf/cm²} is added every 5minutes
Velocity : 1.133m/s{68.0m/min}
Lubrication : grease is applied at the time of assembly

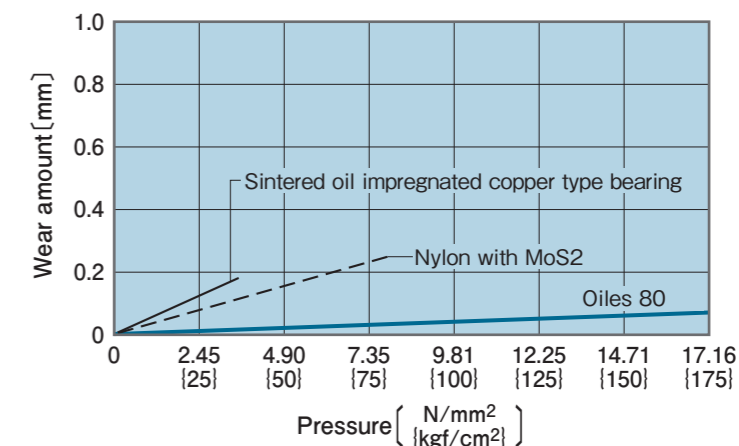
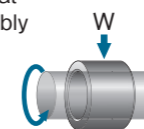

Journal oscillation test

<Testing conditions>
Bearing dimension : φ40×φ50×ℓ30
Mating material : S45C (surface roughness Rz1.5μm)
Pressure : 4.4N/mm²{45.0kgf/cm²}
Velocity : 0.02m/s{1.2m/min}
Oscillating cycle : 72cpm
Oscillating angle : 24°
Lubrication : grease is applied at the time of assembly

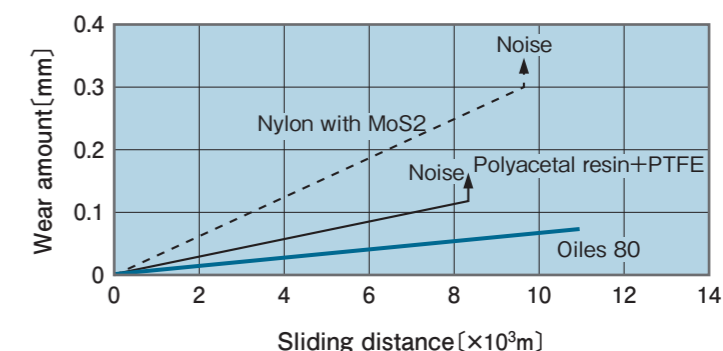
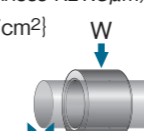

Thrust rotation test

<Testing conditions>
Mating material : S45C (surface roughness Rz3μm)
Pressure : 2.94N/mm²{30.0kgf/cm²}
Velocity : 0.167m/s{10.0m/min}
Test time : 50hrs.
Lubrication : dry

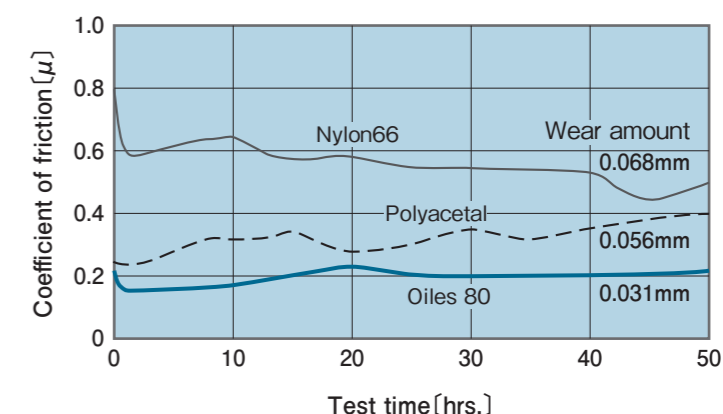
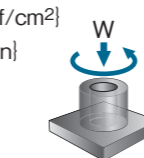

Journal rotation test

<Testing conditions>
Bearing dimension : φ10×φ14×ℓ10
Mating material : SUJ2 (surface roughness approx. Ra0.1μm)
Pressure : 0.98N/mm²{10kgf/cm²}
Velocity : 0.17m/s{10m/min}
Test time : 50hrs.
Lubrication : dry

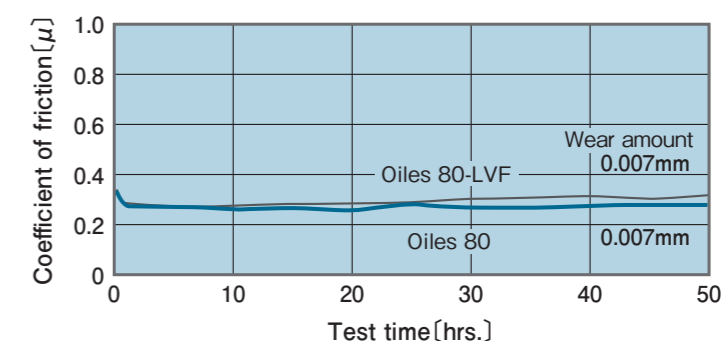
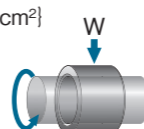

80B Oiles 80 Bushings

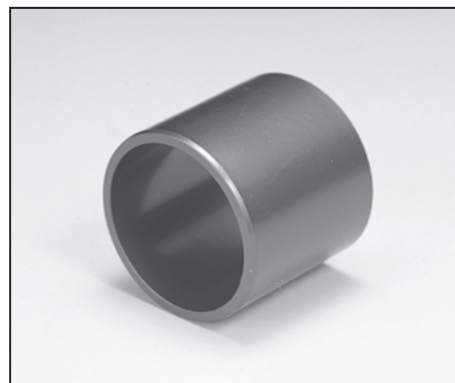

Specify Part No. by required I.D. and length.
(e.g.) I.D. is 15mm and length is 10mm.

80B - 1510

Part No.

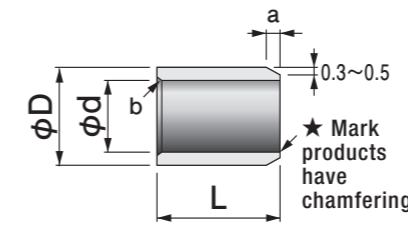
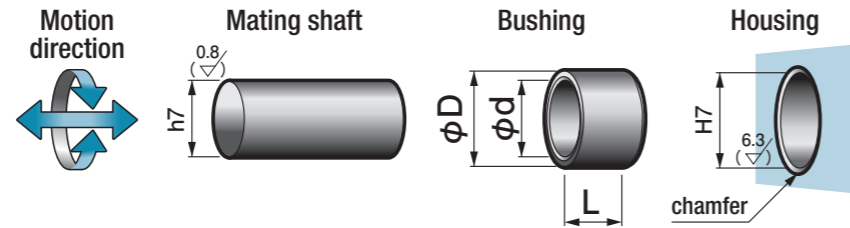

a: Chamfering for O.D.

φd	~6	~35	~50
a	*	1	2

(mm)

b: Chamfering for I.D.

φd	~10	~35	~40	~50
b	C0.3	R0.4	R0.6	R0.8

(mm)

※: O.D. chamfering for the bushing I.D. of φ6 or smaller

L	2	~4	~10
a	0.3	0.5	1 (Note)

(mm)

(Note) 80B-0406 : 0.5, 80B-0604 : 1

- The Oiles 80 bushings are injection-molded.
- The inner diameter tolerances are the values after pressing into a ring gauge of $\phi D \pm 0.002$.
- A stopper is needed at the temperature of 0°C or less, since the bushing is dislocated due to thermal shrinkage.

Shaft		Housing		I.D.		O.D.		Length L Tolerance $-\frac{0}{-0.3}$ (◎ 80B-1510 Tolerance $-\frac{0}{-0.5}$)						
Length	h7 Tolerance	diameter	H7 Tolerance	φd	Tolerance	φD	Tolerance	2	3	4	5	6	8	10
2	$\frac{0}{-0.010}$	4	$\frac{+0.012}{0}$	2	$\frac{+0.065}{+0.015}$	4	$\frac{+0.107}{+0.032}$	0202	0203	0204				
3	$\frac{0}{-0.010}$	5	$\frac{+0.012}{0}$	3	$\frac{+0.080}{+0.030}$	5	$\frac{+0.107}{+0.032}$		0303	0304	0305	0306		
4	$\frac{0}{-0.012}$	6	$\frac{+0.012}{0}$	4	$\frac{+0.095}{+0.045}$	6	$\frac{+0.107}{+0.032}$		0403	0404	0405	0406		
5	$\frac{0}{-0.012}$	7	$\frac{+0.015}{0}$	5	$\frac{+0.095}{+0.045}$	7	$\frac{+0.157}{+0.045}$		0503	0504	0505	0506	0508	
6	$\frac{0}{-0.012}$	8	$\frac{+0.015}{0}$	6	$\frac{+0.095}{+0.045}$	8	$\frac{+0.157}{+0.045}$			0604	0605	0606	0608	0610
7	$\frac{0}{-0.015}$	9	$\frac{+0.015}{0}$	7	$\frac{+0.095}{+0.045}$	9	$\frac{+0.157}{+0.045}$				0705	0706	0708	0710
8	$\frac{0}{-0.015}$	10	$\frac{+0.015}{0}$	8	$\frac{+0.120}{+0.060}$	10	$\frac{+0.157}{+0.045}$				0805	0806	0808	0810
9	$\frac{0}{-0.015}$	11	$\frac{+0.018}{0}$	9	$\frac{+0.120}{+0.060}$	11	$\frac{+0.193}{+0.058}$				0905	0906		0910
10	$\frac{0}{-0.015}$	12	$\frac{+0.018}{0}$	10	$\frac{+0.120}{+0.060}$	12	$\frac{+0.193}{+0.058}$				1005	1006	1008	1010
12	$\frac{0}{-0.018}$	14	$\frac{+0.018}{0}$	12	$\frac{+0.120}{+0.060}$	14	$\frac{+0.193}{+0.058}$					1206	1208	1210
14	$\frac{0}{-0.018}$	16	$\frac{+0.018}{0}$	14	$\frac{+0.120}{+0.060}$	16	$\frac{+0.193}{+0.058}$							1410
15	$\frac{0}{-0.018}$	17	$\frac{+0.018}{0}$	15	$\frac{+0.120}{+0.060}$	17	$\frac{+0.193}{+0.058}$							◎ 1510
16	$\frac{0}{-0.018}$	18	$\frac{+0.018}{0}$	16	$\frac{+0.120}{+0.060}$	18	$\frac{+0.193}{+0.058}$							1610
18	$\frac{0}{-0.018}$	20	$\frac{+0.021}{0}$	18	$\frac{+0.120}{+0.060}$	20	$\frac{+0.221}{+0.071}$							1810
20	$\frac{0}{-0.021}$	23	$\frac{+0.021}{0}$	20	$\frac{+0.145}{+0.075}$	23	$\frac{+0.221}{+0.071}$							
22	$\frac{0}{-0.021}$	25	$\frac{+0.021}{0}$	22	$\frac{+0.145}{+0.075}$	25	$\frac{+0.231}{+0.081}$							
24	$\frac{0}{-0.021}$	27	$\frac{+0.021}{0}$	24	$\frac{+0.145}{+0.075}$	27	$\frac{+0.231}{+0.081}$							
25	$\frac{0}{-0.021}$	28	$\frac{+0.021}{0}$	25	$\frac{+0.170}{+0.090}$	28	$\frac{+0.231}{+0.081}$							
28	$\frac{0}{-0.021}$	32	$\frac{+0.025}{0}$	28	$\frac{+0.170}{+0.090}$	32	$\frac{+0.290}{+0.095}$							
30	$\frac{0}{-0.021}$	34	$\frac{+0.025}{0}$	30	$\frac{+0.170}{+0.090}$	34	$\frac{+0.290}{+0.095}$							
32	$\frac{0}{-0.025}$	36	$\frac{+0.025}{0}$	32	$\frac{+0.215}{+0.115}$	36	$\frac{+0.290}{+0.095}$							
35	$\frac{0}{-0.025}$	39	$\frac{+0.025}{0}$	35	$\frac{+0.215}{+0.115}$	39	$\frac{+0.290}{+0.095}$							
38	$\frac{0}{-0.025}$	42	$\frac{+0.025}{0}$	38	$\frac{+0.215}{+0.115}$	42	$\frac{+0.340}{+0.115}$							
40	$\frac{0}{-0.025}$	44	$\frac{+0.025}{0}$	40	$\frac{+0.215}{+0.115}$	44	$\frac{+0.340}{+0.115}$							
45	$\frac{0}{-0.025}$	50	$\frac{+0.025}{0}$	45	$\frac{+0.235}{+0.135}$	50	$\frac{+0.340}{+0.115}$							
50	$\frac{0}{-0.025}$	55	$\frac{+0.030}{0}$	50	$\frac{+0.235}{+0.135}$	55	$\frac{+0.430}{+0.130}$							

▲ The dimensional tolerances are the values measured at +25°C.

Length L Tolerance $-\frac{0}{-0.5}$							I.D.
12	15	20	25	30	40	50	φd
							2
							3
							4
							5
							6
							7
0812	0815						8
0912	0915						9
1012	1015	1020					10
1212	1215	1220					12
1412	1415	1420					14
1512	1515	1520	1525	1530			15
1612	1615	1620	1625	1630			16
1812	1815	1820	1825	1830			18
	2015	2020	2025	2030			20
		2220		2230			22
	2415	2420	2425				24
	2515	2520	2525	2530			25
		2820	2825	2830			28
		3020	3025	3030	3040		30
		3220 ★		3230 ★	3240 ★		32
		3520	3525 ★	3530 ★	3540 ★		35
		3820		3830	3840		38
		4020	4025	4030	4040	4050	40
		4520		4530	4540	4550	45
		5020		5030	5040	5050	50

80F Oiles 80 Flange Bushings

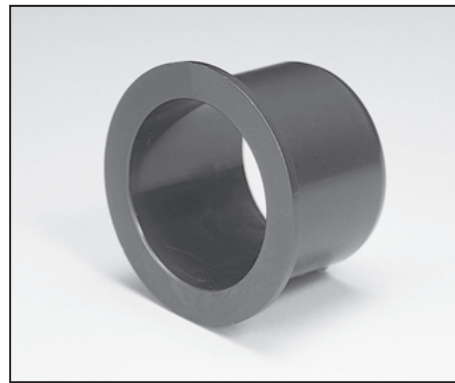

Specify Part No. by required I.D. and length.
(e.g.) I.D. is 15mm and length is 10mm.

80F - 1510
Part No.

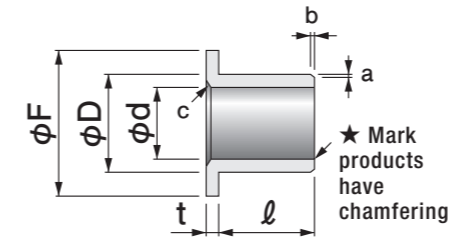
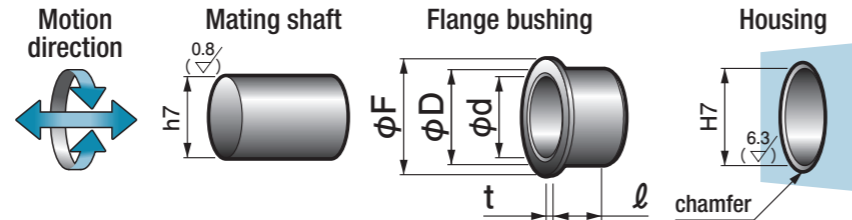

a b: Chamfering for O.D.

φd	2	~35	~50
a	0.3	0.3	0.5
b	(Note)	1	2

(mm)

(Note) ℓ2mm:0.3, ℓ3/4mm:0.5

c: Chamfering for I.D.

φd	~10	~35	~40	~50
c	R0.3	R0.4	R0.6	R0.8

(mm)

- The Oiles 80 bushings are injection-molded.
- The inner diameter tolerances are the values after pressing into a ring gauge of $\phi D \pm 0.002$.
- A stopper is needed at the temperature of 0°C or less, since the bushing is dislocated due to thermal shrinkage.

I.D.		O.D.		Flange			Length ℓ Tolerance $0_{-0.3}$							
φd	Tolerance	φD	Tolerance	φF	t	Tolerance	2	3	4	5	6	7	8	10
2	+0.065 +0.015	4	+0.107 +0.032	6	1	0 -0.10	0202	0203	0204					
3	+0.080 +0.030	5	+0.107 +0.032	8	1	0 -0.10		0303	0304	0305	0306			
4	+0.095 +0.045	6	+0.107 +0.032	9	1	0 -0.10		0403	0404	0405	0406			
5	+0.095 +0.045	7	+0.157 +0.045	10	1	0 -0.10		0503	0504	0505	0506	0507		
6	+0.095 +0.045	8	+0.157 +0.045	12	1	0 -0.10		0603		0605	0606		0608	0610
7	+0.095 +0.045	9	+0.157 +0.045	13	1	0 -0.10		0703		0705		0707		0710
8	+0.120 +0.060	10	+0.157 +0.045	15	1	0 -0.10		0803		0805	0806		0808	0810
9	+0.120 +0.060	11	+0.193 +0.058	16	1	0 -0.10		0903		0905	0906			0910
10	+0.120 +0.060	12	+0.193 +0.058	18	1	0 -0.10		1003		1005	1006		1008	1010
12	+0.120 +0.060	14	+0.193 +0.058	20	1	0 -0.10					1206		1208	1210
14	+0.120 +0.060	16	+0.193 +0.058	22	1	0 -0.10								1410
15	+0.120 +0.060	17	+0.193 +0.058	23	1	0 -0.10								1510
16	+0.120 +0.060	18	+0.193 +0.058	24	1	0 -0.10								1610
18	+0.120 +0.060	20	+0.221 +0.071	26	1	0 -0.10								1810
20	+0.145 +0.075	23	+0.221 +0.071	31	1.5	0 -0.15								2010
22	+0.145 +0.075	25	+0.231 +0.081	33	1.5	0 -0.15								2210
25	+0.170 +0.090	28	+0.231 +0.081	36	1.5	0 -0.15								2510
30	+0.170 +0.090	34	+0.290 +0.095	42	2	0 -0.15								3010
32	+0.215 +0.115	36	+0.290 +0.095	46	2	0 -0.15								
35	+0.215 +0.115	39	+0.290 +0.095	49	2	0 -0.15								3510
38	+0.215 +0.115	42	+0.340 +0.115	52	2	0 -0.15								
40	+0.215 +0.115	44	+0.340 +0.115	54	2	0 -0.15								
45	+0.235 +0.135	50	+0.340 +0.115	60	2.5	0 -0.15								
50	+0.235 +0.135	55	+0.430 +0.130	65	2.5	0 -0.15								

▲ The dimensional tolerances are the values measured at +25°C.

Length ℓ Tolerance $0_{-0.5}$							I.D.
12	15	20	25	30	40	50	φd
							2
							3
							4
							5
							6
							7
0812	0815						8
0912	0915						9
1012	1015	1020					10
1212	1215	1220					12
1412	1415	1420					14
1512	1515	1520	1525	1530			15
1612	1615	1620	1625	1630			16
1812	1815	1820	1825	1830			18
2012	2015	2020	2025	2030			20
	2215	2220	2225	2230			22
2512	2515	2520	2525	2530			25
3012		3020	3025	3030	3040		30
		3220★	3225★	3230★	3240★		32
3512★		3520	3525★	3530	3540		35
		3820		3830	3840		38
4012		4020	4025	4030	4040	4050	40
		4520	4525	4530	4540	4550	45
		5020		5030	5040	5050	50

80W Oiles 80 Washers

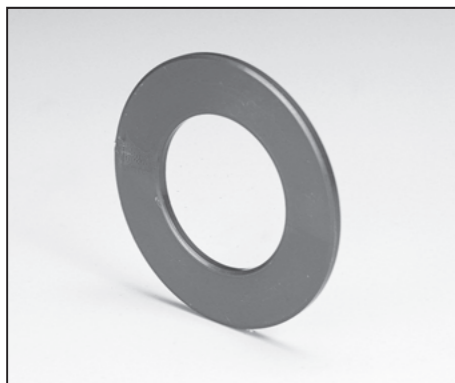

Specify Part No. by required I.D.
(e.g.) I.D. is 15mm.

80W - 15
Part No.

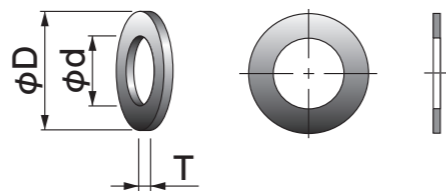

- "If the mating part has coarse surface"
"If foreign matter may be put on the bearing surface"
"If the coefficient of friction should be especially low"

The "plain washers" specified in JIS B1256 may be used as the mating part. In the above cases, however, plastic-to-plastic sliding with overlapped the 80W and 83W is effective.

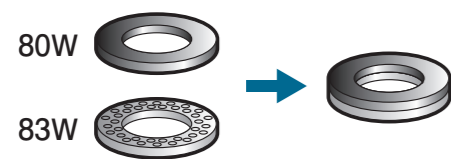

- It is recommended to apply multi-purpose lithium grease of consistency NLGI grade 2 to 0.

Part No.	I.D.		O.D.		Thickness	
	φd	Tolerance	φD	Tolerance	T	Tolerance
80W-08	8.5	±0.3	17	±0.3	1.5	±0.1
80W-10	10.5	±0.3	24	±0.3	2.0	±0.1
80W-12	12.5	±0.3	28	±0.3	2.0	±0.1
80W-15	15	±0.3	28	±0.3	2.0	±0.1
80W-17	17	±0.3	30	±0.3	2.0	±0.1
80W-21	21	±0.3	37	±0.3	2.0	±0.1
80W-23	23	±0.3	39	±0.3	2.0	±0.1
80W-25	25	±0.3	44	±0.3	2.0	±0.1

83W Oiles 83 Washers



Specify Part No. by required I.D.
(e.g.) I.D. is 15mm.

83W - 15
Part No.

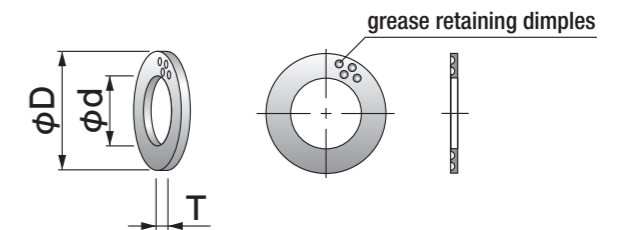

- "If the mating part has coarse surface"
"If foreign matter may be put on the bearing surface"
"If the coefficient of friction should be especially low"

The "plain washers" specified in JIS B1256 may be used as the mating part. In the above cases, however, plastic-to-plastic sliding with overlapped the 80W and 83W is effective.

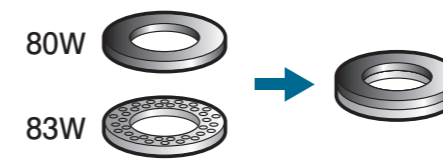

- It is recommended to apply multi-purpose lithium grease of consistency NLGI grade 2 to 0.

Part No.	I.D.		O.D.		Thickness	
	φd	Tolerance	φD	Tolerance	T	Tolerance
83W-08	8.5	±0.3	17	±0.3	1	±0.1
83W-10	10.5	±0.3	24	±0.3	1	±0.1
83W-12	12.5	±0.3	28	±0.3	1	±0.1
83W-15	15	±0.3	28	±0.3	1	±0.1
83W-17	17	±0.3	30	±0.3	1	±0.1
83W-21	21	±0.3	37	±0.3	1	±0.1
83W-23	23	±0.3	39	±0.3	1	±0.1
83W-25	25	±0.3	44	±0.3	1	±0.1

80M Oiles 80 Bar Stock

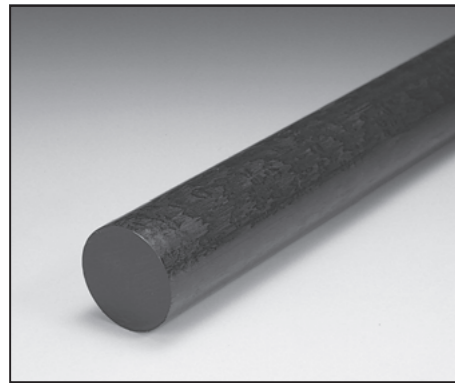

Specify Part No. by required diameter.
(e.g.) Diameter is 36mm.

80M - 35
Part No.



Part No.	Diameter		Length
	φD	Tolerance	L
80M-06	6.5	±0.4	500
80M-10	11	±0.4	500
80M-15	17	±0.4	500
80M-20	21.5	±0.4	500
80M-25	26	±0.4	500
80M-30	31.5	±0.4	500
80M-35	36	±0.5	500
80M-40	41.5	±0.5	500
80M-45	46.5	±0.5	500
80M-50	52	±0.5	500
80M-55	57	±0.5	500
80M-60	61.5	±0.6	500
80M-65	67	±0.6	500

80P Oiles 80 Plate Material



Specify Part No. by required thickness.
(e.g.) Plate thickness is 11mm.

80P - 11
Part No.

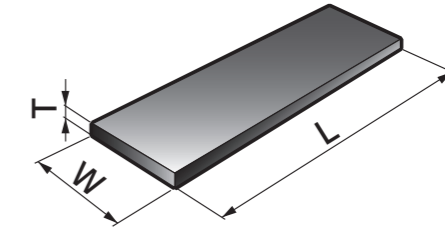

Part No.	Thickness		Width		Length
	T	Tolerance	W	Tolerance	L
80P-08	8	±0.2	105	±0.5	1,000
80P-11	11	±0.2	80	±0.5	1,000
80P-13	13	±0.2	105	±0.5	1,000
80P-18	18	±0.3	105	±0.5	1,000

Selection Guide
Product Information
Plastic Bearing
Multi-layer Bearing
Metallic Bearing
Air Bearings
Slide Shifter
Technical Information
Corporate Profile

Selection Guide
Product Information
Plastic Bearing
Multi-layer Bearing
Metallic Bearing
Air Bearings
Slide Shifter
Technical Information
Corporate Profile

80S

Oiles 80 Pipe Stock

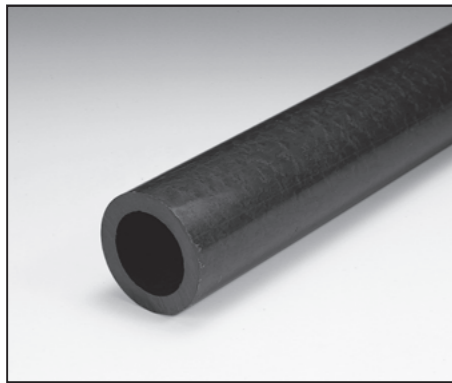

Specify Part No. by required I.D. and O.D.
(e.g.) I.D. is 48.5mm and O.D. is 62.5mm.

80S - 5060

Part No.

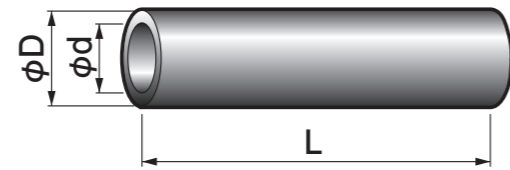

Part No.	I.D.		O.D.		Length L
	φd	Tolerance	φD	Tolerance	
80S-2030	19	±0.4	31.5	±0.4	500
80S-2535	24	±0.4	36.5	±0.4	500
80S-3040	28.5	±0.5	42	±0.5	500
80S-3545	34	±0.5	47	±0.5	500
80S-3550	34	±0.5	52	±0.5	500
80S-4055	38	±0.5	56.5	±0.5	500
80S-4060	38	±0.5	62.5	±0.5	500
80S-4560	43	±0.5	62.5	±0.5	500
80S-4565	43	±0.5	67	±0.6	500
80S-5060	48.5	±0.5	62.5	±0.5	500
80S-5065	48.5	±0.5	67	±0.6	500
80S-5070	48.5	±0.5	72.5	±0.6	500
80S-5565	53.5	±0.6	67.5	±0.6	500
80S-5570	53.5	±0.6	72.5	±0.6	500
80S-5575	53.5	±0.6	78	±0.6	500
80S-6075	58.5	±0.6	78	±0.6	500

Oiles Pillow 80 Unit bearings

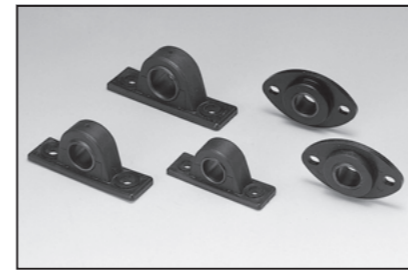

Feature

- Has the same features as 80.
- Demonstrates superior sliding performance in sliding motion.
- The whole bearing unit is made of plastic. Small, lightweight, and superior corrosion resistance.
- The standard products are available in various sizes.

Service range

Operating condition	Intermittent	Continuous
Service temperature range °C	-20~+60	
Allowable max. pressure P N/mm ² (kgf/cm ²)	2.0 {21}	
Allowable max. velocity V m/s (m/min)	0.40 {24}	0.25 {15}
Allowable max. PV value N/mm ² · m/s (kgf/cm ² · m/min)	0.50 {306}	0.30 {184}

80FL Oiles Pillow 80 Flange Units

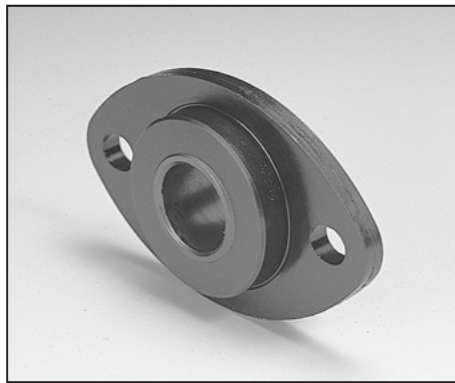

Specify Part No. by required I.D.
(e.g.) Diameter is 12mm.

80FL - 12
Part No.

- The recommended shaft dimension and finishing grade are h7 and Rz3.2µm or less, respectively. The shaft dimension of e7 is recommended if used at the temperature of 0°C (32°F) or less.
- Apply grease or oil to the sliding surface.
- Use bolts and washers to mount the product.
- The allowable tightening torques shown in parentheses are the values if no washer is used.
- Find the surface pressure from the pressure receiving area ($\phi d \times W$), refer to the service ranges shown on page 78, find the allowable load, and choose the proper size.

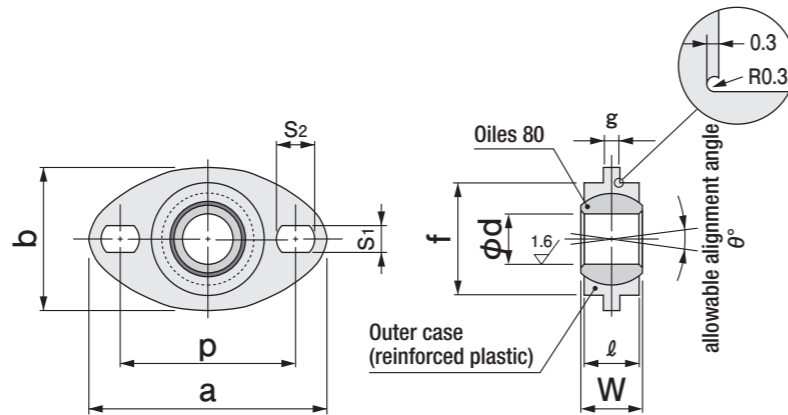

Part No.	I.D.		Outer dimensions						Mounting hole			θ°	Bolt size	Tightening torque (kgf·cm)	
	ϕd	Tolerance	a	b	W	f	Tolerance	g	l	p	S ₁				S ₂
80FL-06	6	+0.068 +0.020	38	20	7	14	0 -0.070	2.5	6	26	4.5	5	13	M4	20 (10)
80FL-08	8	+0.083 +0.025	42	24	10	19	0 -0.084	2.5	9	30	4.5	5	10	M4	25 (15)
80FL-10	10	+0.083 +0.025	48	28	11	22	0 -0.084	3	10	35	5.5	6	8	M5	35 (20)
80FL-12	12	+0.102 +0.032	56	34	13	27	0 -0.100	3	12	42	6.5	7	7	M6	55 (40)
80FL-15	15	+0.102 +0.032	64	40	16	31	0 -0.100	4	15	48	6.5	7.5	6	M6	90 (55)
80FL-17	17	+0.124 +0.040	75	45	18	35	0 -0.160	4.5	16	56	8.5	9.5	11	M8	110 (70)
80FL-20	20	+0.124 +0.040	82	50	20	38	0 -0.160	5	18	63	8.5	10	9	M8	140 (90)

▲ The dimensional tolerances are the values measured at +25°C.

80UP Oiles Pillow 80 Pillow Type Units

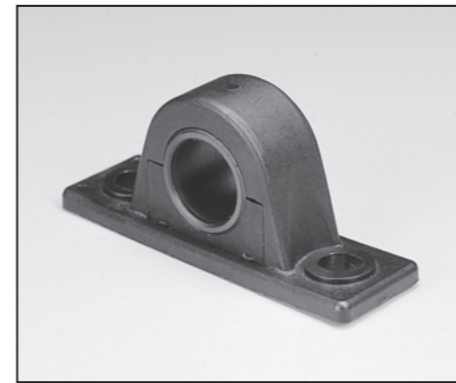

Specify Part No. by required I.D.
(e.g.) Diameter is 12mm.

80UP - 12
Part No.

- The recommended shaft dimension and finishing grade are h7 and Rz3.2µm or less, respectively. The shaft dimension of e7 is recommended if used at the temperature of 0°C (32°F) or less.
- Apply grease or oil to the sliding surface.
- Use bolts and washers to mount the product.
- The allowable tightening torques shown in parentheses are the values if no washer is used.
- Find the surface pressure from the pressure receiving area ($\phi d \times W$), refer to the service ranges shown on page 78, find the allowable load, and choose the proper size.

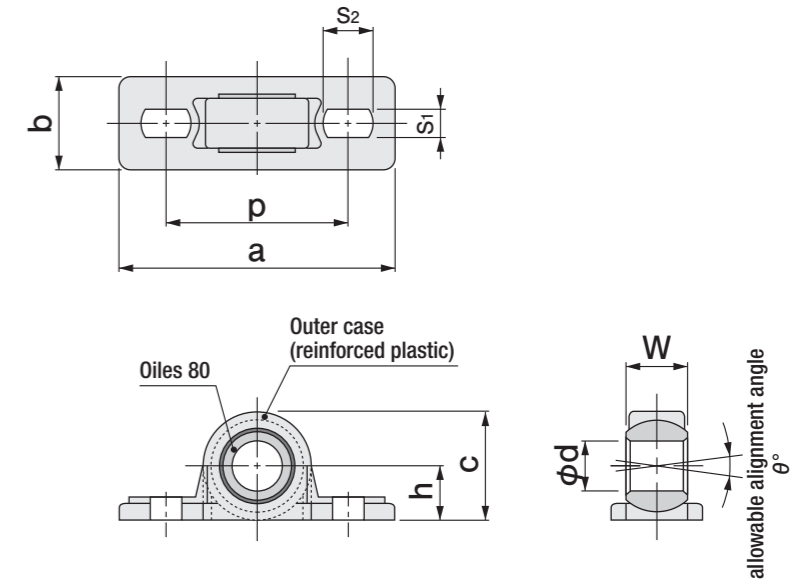

Part No.	I.D.		Outer dimensions					Form			θ°	Bolt size	Tightening torque (kgf·cm)
	ϕd	Tolerance	a	b	W	h	c	p	S ₁	S ₂			
80UP-06	6	+0.068 +0.020	39	12	7	7	14	26	4.5	5	13	M4	20 (15)
80UP-08	8	+0.083 +0.025	45	15	10	9	18	30	4.5	5	10	M4	30 (20)
80UP-10	10	+0.083 +0.025	53	16	11	11	22	36	5.5	6	8	M5	45 (30)
80UP-12	12	+0.102 +0.032	60	18	13	13	26	42	6.5	7	7	M6	75 (50)
80UP-15	15	+0.102 +0.032	67	21	16	15	30	48	6.5	7.5	6	M6	90 (60)
80UP-17	17	+0.124 +0.040	80	24	18	17	34	56	8.5	9.5	11	M8	120 (75)
80UP-20	20	+0.124 +0.040	88	26	20	19	38	63	8.5	10	9	M8	150 (90)

▲ The dimensional tolerances are the values measured at +25°C.

Oiles PS Bearings Plastic sliding bearing units

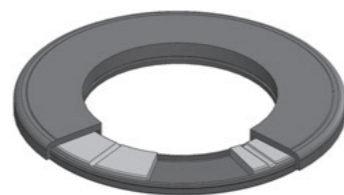

Feature

- Low coefficient of friction. Maintains smooth operating conditions.
- Features low torque variations when starting and stopping and prevents stick slips.
- Has unit structure that slides inside the bearing. Wear of the bearing and the wear characteristics are not affected by the material or surface conditions of the mating parts.
- Demonstrates superior sliding performance in intermittent and sliding operations.
- The whole bearing unit is made of plastic. Small, lightweight, and superior corrosion resistance.
- The standard products are available in various sizes.

Service range

Standard product

Part No.	Service range			Service temperature range °C
	Allowable max. load W N {kgf}	Allowable max. revolution N s ⁻¹ {rpm}	Allowable max. WN value N · s ⁻¹ {kgf · rpm}	
PST-163605	11,700 {1,194}	4.00 {240}	1,470 { 9,000}	-40~+80
PST-204205	16,600 {1,694}	3.50 {210}	1,630 { 9,980}	
PST-254705	19,600 {2,000}	3.00 {180}	1,790 {10,959}	
PST-305205	22,500 {2,296}	2.50 {150}	1,790 {10,959}	
PST-406805	41,100 {4,194}	2.00 {120}	2,450 {15,000}	
PST-507805	49,000 {5,000}	1.50 { 90}	2,450 {15,000}	

(Notes) ※The WN values are the products of the loads and revolutions in operation.

※In oscillating motion, the revolution N found using the conversion expression below must be not more than the allowable maximum revolution.

※Contact us for loads in the radial direction.

$$\text{Revolution } N = (\theta \div 180) \times n$$

N: revolution s⁻¹ {rpm}
 θ: oscillation angle °
 n: oscillation cycle speed s⁻¹ {cpm}

PST Oiles PS Bearings

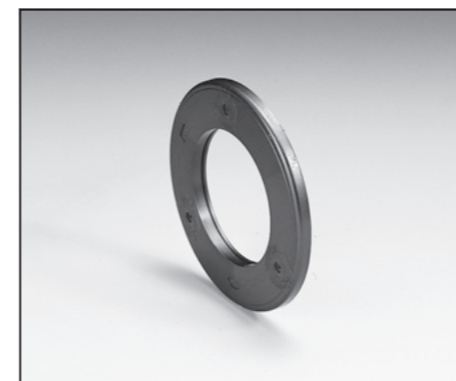

Specify Part No. by required I.D., O.D., and thickness.
(e.g.) I.D. is 25mm, O.D. is 47mm, and thickness is 5mm.

PST - 254705
Part No.

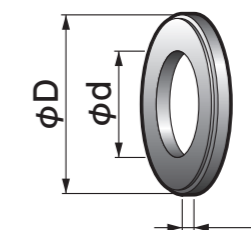

Part No.	I.D.		O.D.	Thickness	
	φd	Tolerance	φD	T	Tolerance
PST-163605	16	+0.18 0	36	5	±0.5
PST-204205	20	+0.21 0	42	5	±0.5
PST-254705	25	+0.21 0	47	5	±0.5
PST-305205	30	+0.21 0	52	5	±0.5
PST-406805	40	+0.25 0	68	5	±0.5
PST-507805	50	+0.25 0	78	5	±0.5

▲ The dimensional tolerances are the values measured at +25°C.

Test data

Thrust oscillation test (Loading test)

<Testing conditions>

Test sample : PST-204205

Rotational frequency : 1s⁻¹

Oscillating cycle : 60cpm

Oscillating angle : ±40°

Ambient temperature : 23°C

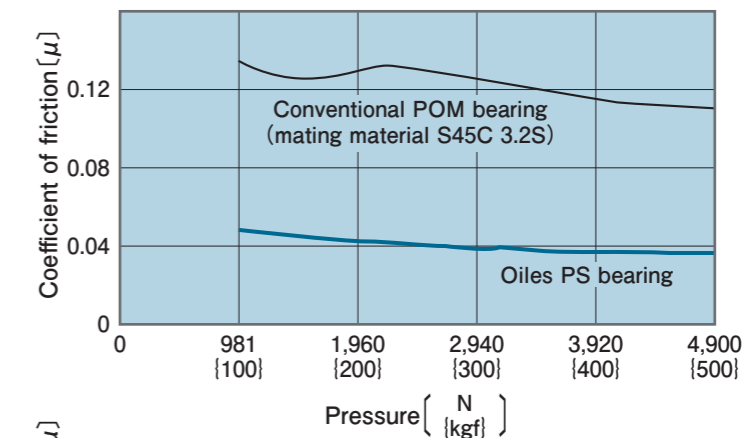

Thrust oscillation test (Temperature dependence)

<Testing conditions>

Test sample : PST-204205

Rotational frequency : 1s⁻¹

Oscillating cycle : 60cpm

Thrust load : 2,450N {250kgf}

Oscillating angle : ±40°

